

# Applied Math for Wastewater Systems

**Course #1201**



Fleming Training Center  
April 27 - May 1, 2020



# Applied Math for Wastewater System Operators

## April 27—May 1, 2020

## Course # 1201

### Monday, April 27:

- 8:30 Solving for the Unknown
- 9:45 Dimensional Analysis and Metric System
- 11:30 Lunch
- 12:30 Circumference, Area, and Volume
- 1:30 Velocity and Flow

### Tuesday, April 28:

- 8:30 Collections and Pretreatment
- 10:00 Chemical Dosage
- 11:30 Lunch
- 12:30 Sedimentation

### Wednesday, April 29:

- 8:30 Trickling Filters
- 9:45 Pumps
- 11:30 Lunch
- 12:30 Laboratory

### Thursday, April 30:

- 8:30 Activated Sludge
- 11:30 Lunch
- 12:30 Sludge Digestion

### Friday, May 1:

- 8:30 Course wrap-up
- 10:00 Exam Review
- 12:00 Final Exam

#### State of Tennessee

Fleming Training Center  
2022 Blanton Dr.  
Murfreesboro, TN

Phone: 615-898-6509  
Fax: 615-898-8064  
E-mail: [Brianne.Begley@tn.gov](mailto:Brianne.Begley@tn.gov)



Department of  
**Environment &  
Conservation**



## **Applied Math for Wastewater Systems**

|            |  |          |
|------------|--|----------|
| Section 1  | Solving for the Unknown                | page 3   |
| Section 2  | Dimensional Analysis and Metric System | page 19  |
| Section 3  | Circumference, Area, and Volume        | page 57  |
| Section 4  | Velocity and Flow                      | page 79  |
| Section 5  | Collections and Pretreatment           | page 97  |
| Section 6  | Chemical Dosage                        | page 121 |
| Section 7  | Sedimentation                          | page 149 |
| Section 8  | Trickling Filters                      | page 181 |
| Section 9  | Pumps                                  | page 213 |
| Section 10 | Laboratory                             | page 241 |
| Section 11 | Activated Sludge                       | page 293 |
| Section 12 | Sludge Digestion                       | page 329 |



## **Section 1**

# **Solving for the Unknown**

# Basic Math Concepts

For Water and Wastewater Plant  
Operators  
by Joanne Kirkpatrick Price

## Suggested Strategy

- ◎ Disregarding all numbers, what type of problem is it?
- ◎ What diagram, if any, is associated with the concept identified?
- ◎ What information is required to solve the problem and how is it expressed in the problem?
- ◎ What is the final answer?
- ◎ Does the answer make sense?



## Solving for the Unknown Value (X)

### Solving for X

◎ Solve for X

$$(4)(1.5)(x) = 1100$$

- X must be by itself on one side of equal sign
- 4 and 1.5 must be moved away from X

$$x = \frac{1100}{(4)(1.5)}$$

$$x = 183.3$$

- How was this accomplished?

## Movement of Terms

- ◎ To understand how we move the numbers, we will need to consider more closely the math concepts associated with moving the terms.
- ◎ An equation is a mathematical statement in which the terms or calculation on one side equals the terms or calculation on the other side.

## Movement of Terms

- ◎ To preserve this equality, anything done to one side of the equation must be done to the other side as well.

$$3x = 14$$

- ◎ Since X is multiplied by 3, you can get rid of the 3 by using the opposite process: division.

## Movement of Terms

- ⦿ To preserve the equation, you must divide the other side of the equation as well.

$$\frac{3x}{\cancel{3}} = \frac{14}{3}$$

$$x = \frac{14}{3}$$

- ⦿ Since both sides of the equation are divided by the same number, the value of the equation remains unchanged.

## Example 1

$$730 = \frac{x}{3847}$$

What you do to one side of the equation, must be done to the other side.

$$730 = \frac{x}{3847} \times \frac{3847}{1}$$

$$\frac{3847}{1} \times 730 = \frac{x}{\cancel{3847}} \times \frac{\cancel{3847}}{1}$$

$$3847 \times 730 = x$$

$$2,808,310 = x$$

## Example 2

Simplify

What you do to one side of the equation, must be done to the other side.

$$0.5 = \frac{(165)(3)(8.34)}{x}$$

$$0.5 = \frac{4128.3}{x}$$

$$0.5 = \frac{4128.3}{x} \times \frac{x}{1}$$

$$\frac{x}{1} \times 0.5 = \frac{4128.3}{\cancel{x}} \times \frac{\cancel{x}}{1}$$

$$(x)(0.5) = 4128.3$$

$$\frac{(x)(\cancel{0.5})}{\cancel{0.5}} = \frac{4128.3}{0.5}$$

$$x = \frac{4128.3}{0.5}$$

$$x = 8256.6$$

## Solving for X<sup>2</sup>

- ◎ Follow same procedure as solving for X
- ◎ Then take the square root

$$x^2 = 15,625$$

$$\sqrt{x^2} = \sqrt{15,625}$$

$$x = 125$$

### Example 3

$$(0.785)(x^2) = 2826$$

$$\frac{(\cancel{0.785})(x^2)}{\cancel{0.785}} = \frac{2826}{0.785}$$

$$x^2 = \frac{2826}{0.785}$$

$$x^2 = 3600$$

$$\sqrt{x^2} = \sqrt{3600}$$

$$x = 60$$

## Fractions and Percents

## Converting Decimals and Fractions

- To convert a fraction to a decimal
  - Simply divide the numerator by the denominator

$$\frac{1}{2} = 1 \div 2 = 0.5$$

$$\frac{10}{13} = 10 \div 13 = 0.7692$$

## Percents and Decimals

- To convert from a decimal to a percent
  - Simply move the decimal point two places to the right

$$0.\overset{\cdot}{4}\overset{\cdot}{6} \Rightarrow 46.0\%$$

- To convert from a percent to a decimal
  - Simply move the decimal two points to the left

$$\overset{\cdot}{7}\overset{\cdot}{9}.5\% \Rightarrow 0.795$$

- Remember:

You CANNOT have a percent in an equation!!

## Writing Equations

- Key words
  - **Of** means “multiply”
  - **Is** means “equal to”
- Calculate 25% of 595,000
 
$$25\% \times 595,000$$

$$0.25 \times 595,000$$

$$148,750$$

## Example 5

448 is what percent of 560?

$$448 = x\% \times 560$$

$$\frac{448}{560} = \frac{x\% \times \cancel{560}}{\cancel{560}}$$

$$0.80 = x\%$$

$$80\% = x$$

# Any Questions?



"Just a darn minute! -- Yesterday  
you said that X equals two!"



## Solving for the Unknown

### Basics – finding x

1.  $8.1 = (3)(x)(1.5)$

2.  $(0.785)(0.33)(0.33)(x) = 0.49$

3.  $\frac{233}{x} = 44$

4.  $940 = \frac{x}{(0.785)(90)(90)}$

5.  $x = \frac{(165)(3)(8.34)}{0.5}$

6.  $56.5 = \frac{3800}{(x)(8.34)}$

7.  $114 = \frac{(230)(1.15)(8.34)}{(0.785)(70)(70)(x)}$

8.  $2 = \frac{x}{180}$

9.  $46 = \frac{(105)(x)(8.34)}{(0.785)(100)(100)(4)}$

10.  $2.4 = \frac{(0.785)(5)(5)(4)(7.48)}{x}$

$$11. 19,747 = (20)(12)(x)(7.48)$$

$$12. \frac{(15)(12)(1.25)(7.48)}{x} = 337$$

$$13. \frac{x}{(4.5)(8.34)} = 213$$

$$14. \frac{x}{246} = 2.4$$

$$15. 6 = \frac{(x)(0.18)(8.34)}{(65)(1.3)(8.34)}$$

$$16. \frac{(3000)(3.6)(8.34)}{(0.785)(x)} = 23.4$$

$$17. 109 = \frac{x}{(0.785)(80)(80)}$$

$$18. (x)(3.7)(8.34) = 3620$$

$$19. 2.5 = \frac{1,270,000}{x}$$

$$20. 0.59 = \frac{(170)(2.42)(8.34)}{(1980)(x)(8.34)}$$

**Finding  $x^2$** 

21.  $(0.785)(D^2) = 5024$

22.  $(x^2)(10)(7.48) = 10,771.2$

23.  $51 = \frac{64,000}{(0.785)(D^2)}$

24.  $(0.785)(D^2) = 0.54$

25.  $2.1 = \frac{(0.785)(D^2)(15)(7.48)}{(0.785)(80)(80)}$

## Percent Practice Problems

Convert the following fractions to decimals:

1.  $\frac{3}{4}$
2.  $\frac{5}{8}$
3.  $\frac{1}{4}$
4.  $\frac{1}{2}$

Convert the following percents to decimals:

5. 35%
6. 99%
7. 0.5%
8. 30.6%

Convert the following decimals to percents:

9. 0.65
10. 0.125
11. 1.0
12. 0.05

Calculate the following:

13. 15% of 125
14. 22% of 450
15. 473 is what % of 2365?
16. 1.3 is what % of 6.5?

## Answers for Solving for the Unknown

### Basics – Finding x

|    |           |     |           |     |         |
|----|-----------|-----|-----------|-----|---------|
| 1. | 1.8       | 8.  | 360       | 15. | 2816.67 |
| 2. | 5.73      | 9.  | 1649      | 16. | 4903.48 |
| 3. | 5.3       | 10. | 244.66    | 17. | 547,616 |
| 4. | 5,976,990 | 11. | 11        | 18. | 117.31  |
| 5. | 8256.6    | 12. | 4.99 or 5 | 19. | 508,000 |
| 6. | 8.06      | 13. | 7993.89   | 20. | 0.35    |
| 7. | 0.005     | 14. | 590.4     |     |         |

### Finding $x^2$

|     |    |     |       |     |       |
|-----|----|-----|-------|-----|-------|
| 21. | 80 | 23. | 39.98 | 25. | 10.94 |
| 22. | 12 | 24. | 0.83  |     |       |

### Percent Practice Problems

|    |       |     |       |     |       |
|----|-------|-----|-------|-----|-------|
| 1. | 0.75  | 7.  | 0.005 | 13. | 18.75 |
| 2. | 0.625 | 8.  | 0.306 | 14. | 99    |
| 3. | 0.25  | 9.  | 65%   | 15. | 20%   |
| 4. | 0.5   | 10. | 12.5% | 16. | 20%   |
| 5. | 0.35  | 11. | 100%  |     |       |
| 6. | 0.99  | 12. | 5%    |     |       |



**Section 2**

**Dimensional Analysis**

**and the Metric**

**System**

# DIMENSIONAL ANALYSIS

MATHEMATICS MANUAL FOR WATER AND  
WASTEWATER TREATMENT PLANT OPERATORS  
BY FRANK R. SPELLMAN

## DIMENSIONAL ANALYSIS

- Used to check if a problem is set up correctly
- Work with the units of measure, not the numbers
- Units in the numerator are divided out with similar units in the denominator
- Step 1:
  - Express fraction in a vertical format

$$gal/ft^3 \text{ to } \frac{gal}{ft^3}$$

$$psi \text{ to } \frac{lbs}{in^2}$$



## DIMENSIONAL ANALYSIS

- Step 2:

- Be able to divide a fraction

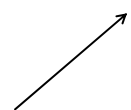
$$\frac{\frac{lb}{day}}{\frac{min}{day}} \text{ becomes } \frac{lb}{day} \times \frac{day}{min}$$

- This is called a “complex fraction”

- Fractions within fractions
- **Invert the denominator and multiply**

## DIMENSIONAL ANALYSIS

- Step 3:

- Know how to divide terms in the numerator and denominator
- Like terms can cancel each other out
  - For every term that is canceled in the numerator, a similar term must be canceled in the denominator

$$\frac{Kg}{day} \times \frac{day}{min} = \frac{Kg}{min}$$

- Units with exponents should be written in expanded form

$$ft^3 = (ft)(ft)(ft)$$

### EXAMPLE 1

- Convert 1800 ft<sup>3</sup> into gallons.
- Use the factor 7.48 gal/ft<sup>3</sup>
- Would we divide or multiply? Use only the dimensions first to determine the correct setup.

- Divide  $\frac{ft^3}{gal/ft^3} = \frac{ft^3}{\frac{gal}{ft^3}}$

$$ft^3 \times \frac{ft^3}{gal} = \frac{ft^6}{gal} \quad \times$$

- Multiply  $\frac{ft^3 \times gal}{ft^3}$   
gal ✓

### EXAMPLE 1 CONTINUED

- Plug in numbers
  - Multiply factor to achieve answer

$$1800 ft^3 \times 7.48 \frac{gal}{ft^3}$$

$$13,464 gal$$

## EXAMPLE 2

- Determine the square feet given  $70 \text{ ft}^3/\text{sec}$  and  $4.5 \text{ ft}/\text{sec}$
- Use units to determine set up
  - Multiply

$$\frac{\text{ft}^3}{\text{sec}} \times \frac{\text{ft}}{\text{sec}} = \frac{\text{ft}^4}{\text{sec}^2} \quad \times$$

- Divide

$$\frac{\frac{\text{ft}^3}{\text{sec}}}{\frac{\text{ft}}{\text{sec}}} = \frac{\text{ft}^3}{\text{sec}} \times \frac{\text{sec}}{\text{ft}}$$

$$\frac{(\cancel{\text{ft}})(\cancel{\text{ft}})(\text{ft})}{\cancel{\text{sec}}} \times \frac{\cancel{\text{sec}}}{\cancel{\text{ft}}}$$

$$\text{ft}^2 \quad \checkmark$$

## EXAMPLE 2 CONTINUED

- Plug in numbers
  - Divide to achieve answer

$$\frac{70 \text{ ft}^3/\text{sec}}{4.5 \text{ ft}/\text{sec}}$$

$$15.56 \text{ ft}^2$$

## ANY QUESTIONS?

© MARK ANDERSON WWW.ANDERSTOONS.COM



"To show you how well I understand fractions,  
I only did half of my homework."

## REFERENCES

- *Mathematics Manual for Water and Wastewater Treatment plant Operators* by Frank R. Spellman
- *Basic Math Concepts for Water and Wastewater Plant Operators* by Joanne Kirkpatrick Price

## Basic Math Dimensional Analysis

Dimensional analysis is not just a way to work math problems. It is an easy way to verify that your formula is set up properly before the calculation is performed.

Rules to follow:

- ✓ Units written in abbreviated or horizontal form should be rewritten in a vertical format. For example:

$$\text{cfs} \Rightarrow \frac{\text{ft}^3}{\text{sec}} \qquad \text{gal/cu ft} \Rightarrow \frac{\text{gal}}{\text{ft}^3}$$

- ✓ Any unit that is a common factor to both the numerator and denominator of a fraction may be divided out. For example:

$$\left( \frac{20 \text{ ft}^3}{\text{sec}} \right) \left( \frac{60 \text{ sec}}{\text{min}} \right) = \frac{(20)(60)\text{ft}^3}{\text{min}}$$

- ✓ An exponent of a unit indicates how many times that unit is to be multiplied together. For example:

$$\text{ft}^3 = (\text{ft})(\text{ft})(\text{ft})$$

- Sometimes it is necessary to write terms with exponents in expanded form, while other times it is advantageous to keep the unit in exponent form. This choice depends on which other units are part of the calculation and how these units might divide out.

Remember: Fractions must be multiplied or divided to do any canceling. Fractions that are added and subtracted can't be cancelled.

**Basics:**

Use dimensional analysis to determine the **units** of the answers:

1.  $(0.785)(\text{ft})(\text{ft})(\text{ft})$

2.  $(120 \text{ ft}^3/\text{min})(1440 \text{ min}/\text{day})$

3.  $\frac{(8\text{ft})(10\text{ft})(x\text{ft})}{\text{sec}}$

Verify the mathematical setup for each problem. If the setup is incorrect, correct the setup:

4.  $(1.6 \text{ fpm})(60 \text{ sec}/\text{min}) = \text{fps}$

5.  $(70 \text{ in})(1 \text{ ft}/12 \text{ in})(0.3048 \text{ m}/\text{ft}) = \text{m}$

5. Correct

4. Incorrect

3.  $\text{ft}^3/\text{sec}$ 2.  $\text{ft}^3/\text{day}$ 1.  $\text{ft}^3$

## Complex Fractions:

- ✓ When the units of a given problem are written as a complex fraction:
  - o Invert the denominator and multiply. For example:

$$\frac{2,808,000 \text{ gpd}}{1440 \text{ min/day}} = \frac{\frac{\text{gal}}{\text{day}}}{\frac{\text{min}}{\text{day}}} = \left( \frac{\text{gal}}{\text{day}} \right) \left( \frac{\text{day}}{\text{min}} \right)$$

- o Shortcut: If the numerator is the same in both the top and bottom fractions, they will cancel when the bottom fraction inverts and multiplies. The same goes if the denominator is the same in both the top and the bottom fractions.

Use dimensional analysis to determine the **units**:

1.  $\frac{(4140 \text{ gpm})}{(60 \text{ sec/min})}$
2.  $\frac{(880 \text{ cu ft})(1440 \text{ min/day})}{6.2 \text{ cu ft/day}}$
3.  $\frac{587 \text{ gal}}{246 \text{ gph}}$

Verify the mathematical setup for each problem. If the setup is incorrect, correct the setup:

$$4. \frac{(40 \text{ in})(1.5 \text{ ft})(2.3 \text{ fpm})}{12 \text{ in/ft}} = \text{cfm}$$

$$5. \left( \frac{2,400,000 \text{ gpd}}{7.48 \text{ gal/ft}^3} \right) \frac{1}{635,400 \text{ ft}^2} = \text{ft/day}$$

1. gal/sec      2. min      3. hour      4. ft<sup>2</sup>/min      5. ft/day

## General Conversions

1.  $325 \text{ ft}^3 =$  gal

2.  $2512 \text{ kg} =$  lb

3.  $2.5 \text{ miles} =$  ft

4.  $1500 \text{ hp} =$  kW

5.  $2.2 \text{ ac-ft} =$  gal

6.  $21 \text{ ft}^2 =$  ac

7.  $92.6 \text{ ft}^3 =$  lb

8.  $17,260 \text{ ft}^3 =$  MG

9.  $0.6\% =$  mg/L

10.  $30 \text{ gal} =$   $\text{ft}^3$

11. A screening pit must have a capacity of  $400 \text{ ft}^3$ . How many lbs is this?

12. A reservoir contains 50 ac-ft of water. How many gallons of water does it contain?



13. 3.6 cfs = gpm

14. 1820 gpm = gpd

15. 45 gps = cfs

16. 8.6 MGD = gpm

17. 2.92 MGD = lb/min

18. 385 cfm = gpd

19. 1,662 gpm = lb/day

20. 3.77 cfs = MGD

21. The flow through a pipeline is 8.4 cfs. What is the flow in gpd?

22. A treatment plant receives a flow of 6.31 MGD. What is the flow in cfm?

## Basic Conversions - Extra Problems

1. How many seconds are in a minute?
2. How many minutes are in an hour?
3. How many hours in a day?
4. How many minutes in a day?
5. How many inches in a foot?
6. How many feet in a mile?
7. How many feet in a yard?
8. How many yards in a mile?
9. How much does one gallon of water weigh?
10. How much does one cubic foot of water weigh?

11. Express a flow of 5 cfs in terms of gpm.
  
  
  
  
  
  
  
  
  
  
12. What is 38 gps expressed as gpd?
  
  
  
  
  
  
  
  
  
  
13. What is 0.7 cfs expressed as gpd?
  
  
  
  
  
  
  
  
  
  
14. What is 9164 gpm expressed as cfs?
  
  
  
  
  
  
  
  
  
  
15. What is 1.2 cfs expressed as MGD?
  
  
  
  
  
  
  
  
  
  
16. Convert 65 gpm into lbs/day.
  
  
  
  
  
  
  
  
  
  
17. Convert 345 lbs/day into gpm.

18. Convert 0.9 MGD to cfm.
  
19. Convert 1.2 MGD to  $\text{ft}^3/\text{hour}$ .
  
20. Convert a flow of 4,270,000 gpd to cfm.
  
21. What is 5.6 MGD expressed as cfs?
  
22. Express 423,690 cfd as gpm.
  
23. Convert 2730 gpm to gpd.
  
24. Convert 1440 gpm to MGD.
  
25. Convert 45 gps to  $\text{ft}^3/\text{day}$ .

**General Conversions**

1. 2,431 gal
2. 5,533.04 lb
3. 13,200 ft
4. 1,119 kW
5. 717,200 gal
6. 0.0005 ac
7. 5,778.24 lb
8. 0.13 MG
9. 6,000 mg/L
10. 4.01 ft<sup>3</sup>
11. 24,960 lb
12. 16,300,000 gal
13. 1,615.68 gal/min
14. 2,620,800 gal/day
15. 6.02 gal/sec
16. 5,968.4 gpm
17. 16,911.67 lb/min
18. 4,416,912 gal/day
19. 19,959,955.2 lb/day
20. 2.43 MGD
21. 5,428,684.8 gal/day
22. 585.82 ft<sup>3</sup>/min

**Basic Conversions Extra Problems**

1. 60 sec/min
2. 60 min/hr
3. 24 hr/day
4. 1440 min/day
5. 12 in/ft
6. 5280 ft/mi
7. 3 ft/yd
8. 1760 yd/mi
9. 8.34 lbs/gal
10. 62.4 lbs/ft<sup>3</sup>
11. 2244 gpm
12. 3,283,200 gpd
13. 452,390 gpd
14. 20.42 cfs
15. 0.78 MGD
16. 780,624 lbs/day
17. 0.03 gpm
18. 83.56 ft<sup>3</sup>/min
19. 6684.49 ft<sup>3</sup>/hr
20. 396.43 ft<sup>3</sup>/min
21. 8.67 cfs
22. 2,200.83 gpm
23. 3,931,200 gpd
24. 2.07 MGD
25. 519,786.10 ft<sup>3</sup>/day

**Additional Conversion Problems**

1. Convert 723 gallons to liters
2. Convert 17°C to degrees Fahrenheit.
3. How many feet are in 2.5 miles?
4. Convert 56 grains per gallon to mg/L.
5. Convert 56 ft<sup>3</sup>/s to gallons per minute.
6. Convert 34°C to degrees Fahrenheit.
7. Calculate 42.0% of 7,310.
8. Convert 72 ppm to percent.
9. A solution was found to be 7.6% hypochlorite. How many milligrams per liter of hypochlorite are in the solution?
10. Convert 8.77 acre-ft to gallons.
11. Convert 1.98 acres to square feet.

12. Convert  $81 \text{ ft}^3$  to gallons and liters.
13. Convert  $212^\circ\text{F}$  to degrees Celsius.
14. Convert 1472 L to gallons.
15. Convert 0.25 miles to yds.
16. Convert a chlorine solution of 2.5 ppm to percent.
17. Convert 2,367 g to pounds.
18. Convert 3.45 MGD to cubic feet per second.
19. Convert 63.5% to ppm.
20. What percent is 12,887 of 475, 258?

Convert the following:

21.  $451^\circ\text{F}$  to degrees Celsius
22. 8,711,400 gal to cubic feet and acre-feet.
23. 35 cfs to gpm

24. 8 lb/sec to lb/day

25. 45 gla/min to ft<sup>3</sup>/day

26. 927 cfm to gps

27. 0.3 MGD to gal/hr

28. 89 cfd to cfs

29. 93 gal/sec to MGD

30. 2 ft<sup>3</sup>/min to gal/day

31. 17 gal/day to lb/min

32. 1.7 acre-foot to gal

33. 78 mg/l to lbs/gal

34. 890 lb/day to cfm

35. 106 gpd to ft<sup>3</sup>/sec



36. 9 grams to lbs

37. 29.78 lb/hr to gpd

38. 79 mL to gal

39. 830 yds/min to ft/day

40. 379 km/day to mph

**Conversion Answers:**

1. 191 L
2. 62.6°F
3. 13,200 ft
4. 958.6 mg/L
5. 25,132.8 gpm
6. 93.2°F
7. 3,070.2
8. 0.0072%
9. 76,000
10. 2,857,518.6 gal
11. 86,248.8 ft<sup>2</sup>
12. 2,293.3 L
13. 100.1°C
14. 388.9 gal
15. 440 yd
16. 0.00025%
17. 5.2 lb
18. 5.4 cfs
19. 635,000 mg/L
20. 2.7%
21. 233°C
22. 26.7 ac-ft
23. 15,708 gpm
24. 691,200 lb/day
25. 8,663.1 cfd
26. 115.6 gps
27. 12,500 gal/hr
28. 0.001 cfs
29. 8.03 MGD
30. 21,542.4 gpd
31. 0.1 lb/min
32. 553, 909 gal
33. 0.0007 lb/gal
34. 0.074 cfm
35. 0.0016 cfs
36. 0.019 lb
37. 85.7 gpd
38. 0.02 gal
39. 3,585,600 ft/day
40. 1.72 mi/day

# Metric System

Applied Math for Wastewater Systems



{ 1 }

## Is the English System Easier?

- 12 inches = 1 foot
  - 3 feet = 1 yard
  - 5280 feet = 1 mile
  - 2 pints = 1 quart
  - 4 quarts = 1 gallon
  - 16 ounces = 1 pound
  - 32 fluid ounces = 1 quart
- 
- A foot determined by the size of a person's foot, there wasn't a standard
  - Confusing numbers, nothing repeats

{ 2 }

## History

- By the eighteenth century, dozens of different units of measurement were commonly used throughout the world
- Length, for example, could be measured in feet, inches, miles, spans, cubits, hands, furlongs, palms, rods, chains, leagues, and more
- The lack of common standards led to a lot of confusion and significant inefficiencies in trade between countries

{ 3 }

## History

- At the end of the century, the French government sought to alleviate this problem by devising a system of measurement that could be used throughout the world
- In 1790, the French National Assembly commissioned the Academy of Science to design a simple decimal-based system of units; the system they devised is known as the metric system

{ 4 }

## History

- In 1960, the metric system was officially named the *Système International d'Unités* (or SI for short) and is now used in nearly every country in the world except the United States
- The metric system is almost always used in scientific measurement

{ 5 }

## Metric System Simplicity

- There is only one unit of measurement for each type of quantity measured
  - Length
  - Mass (weight)
  - Volume
  - Concentration
  - Temperature

{ 6 }

## The Metric System

- The metric system is founded on base units.
  - The base unit of mass is the **gram**.
  - The base unit of length is the **meter**.
  - The base unit of volume is the **Liter**.
- To go from small to large quantities the base units are described by prefixes which represent a power of ten.

7

## Metric System Simplicity

- The meter is a unit of length equal to 3.28 feet
- The gram is a unit of mass equal to approximately 0.0022 pounds
- The liter is a unit of volume equal to 1.05 quarts.
- Volume is always measured in liters, whether you are measuring how much water you need for a chlorine test or how much water is in your clarifier or sedimentation basin.

[ 8 ]

# Metric System

- Based on the decimal system
- All units of length, volume, and weight use factors of 10
- To express smaller amounts, prefixes are added to the names of the metric units
  - Milli- ( $1/1000^{\text{th}}$  of or 0.001 times)
  - Centi- ( $1/100^{\text{th}}$  of or 0.01 times)

{ 9 }

| <u>Prefix</u>             | <u>Symbol</u> | <u>It means</u> | <u>What it means in words</u> |
|---------------------------|---------------|-----------------|-------------------------------|
| <b>mega</b>               | M             | 1 000 000       | One million                   |
| <b>kilo</b>               | k             | 1 000           | One thousand                  |
| <b>hecto</b>              | h             | 100             | One hundred                   |
| <b>deka</b>               | da            | 10              | Ten                           |
| <b>-- Primary Unit --</b> |               |                 |                               |
| <b>deci</b>               | d             | 0.1             | One Tenth                     |
| <b>centi</b>              | c             | 0.01            | One hundredth                 |
| <b>milli</b>              | m             | 0.001           | One thousandth                |
| <b>micro</b>              | μ             | 0.000 001       | One millionth                 |
| <b>nano</b>               | n             | 0.000 000 001   | One billionth                 |

10



**Convert 0.5 L into mL.**  
**Large to small (multiply)**

Kilo - means 1,000  
 Hecto - means 100  
 Dekka - means 10  
 Chart works around the ones place e.g. 1 meter, gram or liter  
 Deci - means 1/10 or 0.1  
 Centi - means 1/100 or 0.01  
 Milli - means 1/1000 or 0.001

0.5 L  $\xrightarrow{\times 10}$   $\xrightarrow{\times 10}$   $\xrightarrow{\times 10}$  = **500 mL**

To convert Up - **Divide** by 10  
 Down **Multiply** by 10

11



**Convert 8,540 grams into Kg.**  
**Small to large (divide)**

Kilo - means 1,000  
 Hecto - means 100  
 Dekka - means 10  
 Chart works around the ones place e.g. 1 meter, gram or liter  
 Deci - means 1/10 or 0.1  
 Centi - means 1/100 or 0.01  
 Milli - means 1/1000 or 0.001

8,540 g  $\xrightarrow{\div 10}$   $\xrightarrow{\div 10}$   $\xrightarrow{\div 10}$  = **8.54 Kg**

To convert Up - **Divide** by 10  
 Down **Multiply** by 10

12



- All units can be converted into smaller or larger units by moving a decimal point

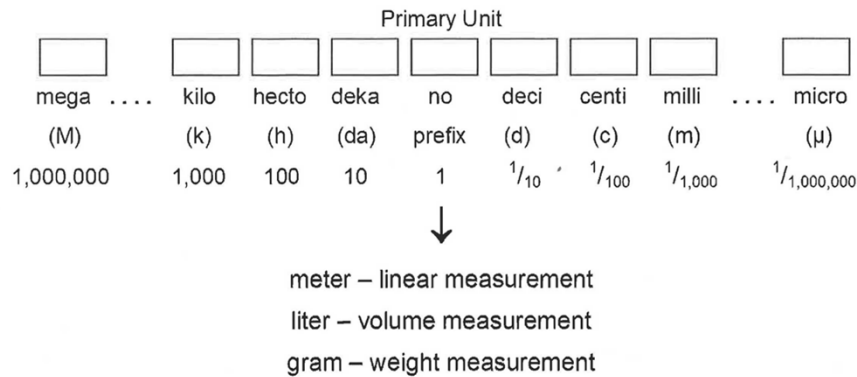

{ 13 }

## Example 1

- Convert 1 meter to decimeters (dm)

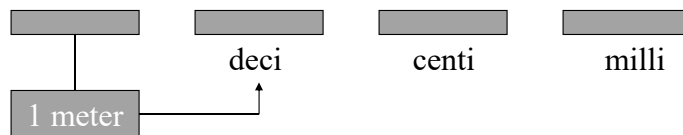

- Converting from meters to decimeters requires moving one place to the right, therefore, move the decimal point from its present position one place to the right as well.

{ 14 }

## Example 1

- Convert 1 meter to decimeters (dm)

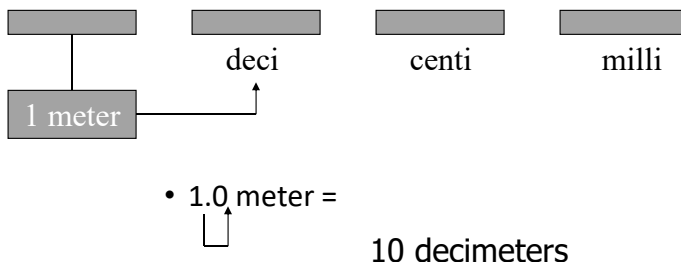

{ 15 }

## Example 2

- Convert 1 gram to milligrams (mg)

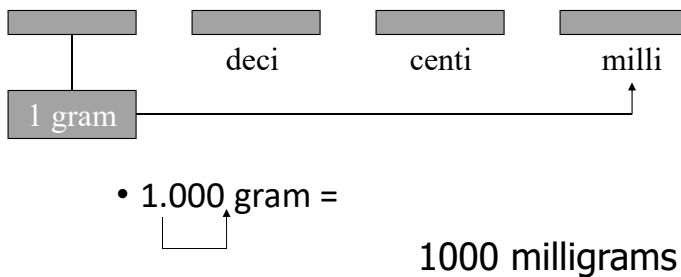

{ 16 }

## Example 3

- Convert 0.28 cm to meters

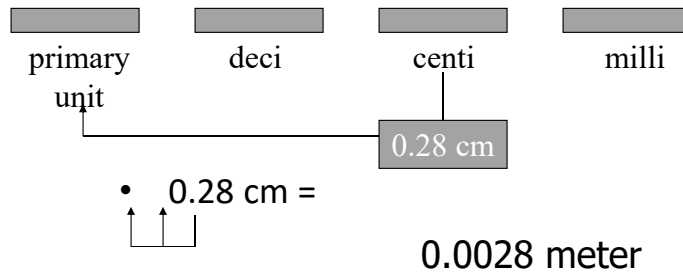

{ 17 }

## Example 4

- Convert 2500 milliliters to liters

| Primary Unit |       |      |        |                |                 |                   |
|--------------|-------|------|--------|----------------|-----------------|-------------------|
| □            | □     | □    | □      | □              | □               | □                 |
| kilo         | hecto | deka | no     | deci           | centi           | milli             |
| (k)          | (h)   | (da) | prefix | (d)            | (c)             | (m)               |
| 1,000        | 100   | 10   | 1      | $\frac{1}{10}$ | $\frac{1}{100}$ | $\frac{1}{1,000}$ |

- Converting milliliters to liters requires a move of three place values to the left
- Therefore, move the decimal point 3 places to the left

$$2\ 5\ 0\ 0. = 2.5\ \text{Liters}$$

$\begin{array}{c} \uparrow \uparrow \uparrow \\ 3\ 2\ 1 \end{array}$

{ 18 }

## Metric Conversion

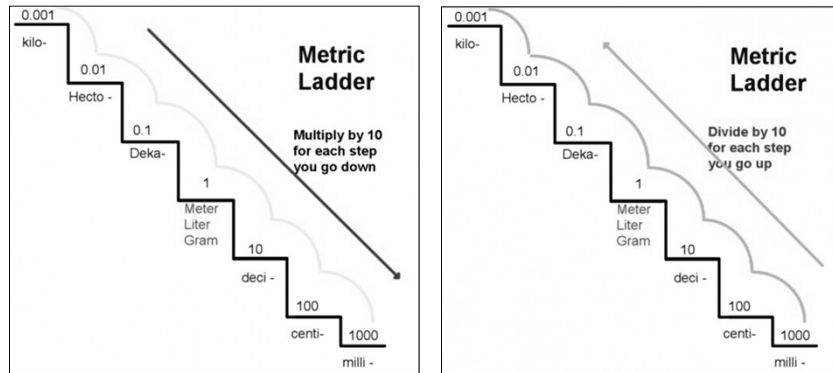

When converting any type of measures

- To convert from a **larger to smaller** metric unit you always **multiply**
- To convert from a **smaller to larger** unit you always **divide**

[ 19 ]

TEMPERATURE

[ 20 ]

## Temperature – Fahrenheit

- The **Fahrenheit** scale is named for the 18th-century German physicist Daniel Fahrenheit.
- His scale is based on 32 for the freezing point of water and 212 for the boiling point of water
- The scale was in common use in English speaking countries until the 1970's when Europe and Canada adopted the centigrade (Celsius) scale.
- The U.S is the only country that still uses the Fahrenheit scale.

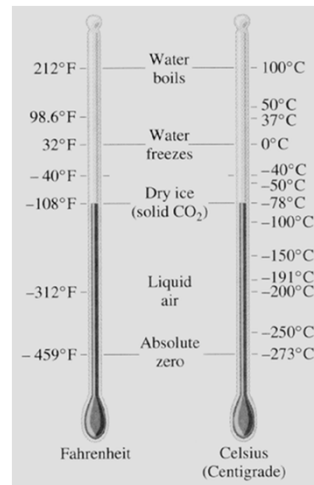

{ 21 }

## Temperature - Celsius

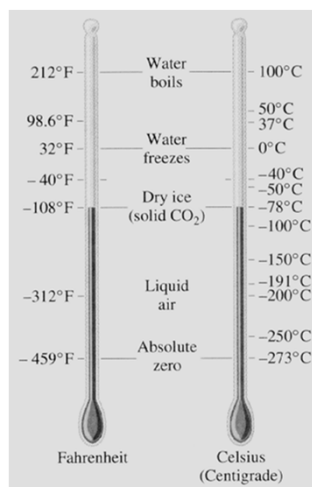

- The **Celsius** temperature scale is named for the Swedish astronomer Anders Celsius who invented the scale in 1742.
- The scale is based on 0 for the freezing point of water and 100 for the boiling point of water.
- It is sometimes called the **centigrade** scale because of the 100-degree interval between the defined points.

{ 22 }

## Temperature

- To convert Celsius ( $^{\circ}\text{C}$ ) into Fahrenheit ( $^{\circ}\text{F}$ ):

$$^{\circ}\text{F} = (^{\circ}\text{C})(1.8) + 32$$

- To convert Fahrenheit ( $^{\circ}\text{F}$ ) into Celsius ( $^{\circ}\text{C}$ ):

$$^{\circ}\text{C} = (0.556)(^{\circ}\text{F} - 32)$$

or

$$^{\circ}\text{C} = \frac{(^{\circ}\text{F} - 32)}{1.8}$$

{ 23 }

## Temperature Conversions

- You just won free tickets for an all-inclusive paid trip to Scotland! You are planning your wardrobe based on the weather forecast that predicts the temperature to be  $21^{\circ}\text{C}$  all week. Should you pack your wool sweaters or your t-shirts?

- $^{\circ}\text{F} = (^{\circ}\text{C})(1.8) + 32$
- $^{\circ}\text{F} = (21^{\circ}\text{C})(1.8) + 32$
- $^{\circ}\text{F} = 37.8 + 32$
- $^{\circ}\text{F} = 69.8$



{ 24 }

## Temperature Conversions

- You are recording your BOD incubator temperature for the day. Someone replaced your Celsius thermometer with a Fahrenheit thermometer. The temperature reading is 68 degrees F. What is the temperature in Celsius?

- $^{\circ}\text{C} = (0.556)(^{\circ}\text{F} - 32)$
- $^{\circ}\text{C} = (0.556)(^{\circ}68 - 32)$
- $^{\circ}\text{C} = (0.556)(36)$
- $^{\circ}\text{C} = 20.016$



{ 25 }

Any Questions?

{ 26 }

## Metric Conversion Equations

### Linear Measure

|              |   |               |
|--------------|---|---------------|
| 1 centimeter | = | 0.3937 inches |
| 1 meter      | = | 3.281 feet    |
| 1 meter      | = | 1.0936 yards  |
| 1 kilometer  | = | 0.6214 miles  |

|        |   |          |
|--------|---|----------|
| 1 inch | = | 2.540 cm |
| 1 foot | = | 0.3048 m |
| 1 yard | = | 0.9144 m |
| 1 mile | = | 1.609 km |

### Square Measure

|                   |   |                       |
|-------------------|---|-----------------------|
| 1 cm <sup>2</sup> | = | 0.155 in <sup>2</sup> |
| 1 m <sup>2</sup>  | = | 35.3 ft <sup>2</sup>  |
| 1 m <sup>2</sup>  | = | 1.196 yd <sup>2</sup> |

|                   |   |                        |
|-------------------|---|------------------------|
| 1 in <sup>2</sup> | = | 6.4516 cm <sup>2</sup> |
| 1 ft <sup>2</sup> | = | 0.0929 m <sup>2</sup>  |
| 1 yd <sup>2</sup> | = | 0.8361 m <sup>2</sup>  |

### Cubic Measure

|                  |   |                       |
|------------------|---|-----------------------|
| 1cm <sup>3</sup> | = | 0.061 in <sup>3</sup> |
| 1 m <sup>3</sup> | = | 35.3 ft <sup>3</sup>  |
| 1 m <sup>3</sup> | = | 1.308 yd <sup>3</sup> |

|                   |   |                       |
|-------------------|---|-----------------------|
| 1 in <sup>3</sup> | = | 16.39 cm <sup>3</sup> |
| 1 ft <sup>3</sup> | = | 0.0283 m <sup>3</sup> |
| 1 yd <sup>3</sup> | = | 0.7645 m <sup>3</sup> |

### Capacity

|         |   |                        |
|---------|---|------------------------|
| 1 Liter | = | 61.025 in <sup>3</sup> |
| 1 Liter | = | 0.0353 ft <sup>3</sup> |
| 1 Liter | = | 0.2642 gal             |

|                   |   |          |
|-------------------|---|----------|
| 1 in <sup>3</sup> | = | 0.0164 L |
| 1 ft <sup>3</sup> | = | 28.32 L  |
| 1 gal             | = | 3.785 L  |

### Weight

|            |   |               |
|------------|---|---------------|
| 1 gram (g) | = | 15.43 grains  |
| 1 gram     | = | 0.0353 ounces |
| 1 kilogram | = | 2.205 pounds  |

|         |   |          |
|---------|---|----------|
| 1 grain | = | 0.0648 g |
| 1 ounce | = | 28.35 g  |
| 1 pound | = | 456.6 g  |



**Metric Conversions**

1. 1 m = \_\_\_\_\_ cm
  2. 1 g = \_\_\_\_\_ mg
  3. 1 kg = \_\_\_\_\_ g
  4. 1 cm = \_\_\_\_\_ mm
  5. 10 cm = \_\_\_\_\_ mm
  6. 50 cm = \_\_\_\_\_ mm
  7. 8 km = \_\_\_\_\_ m
  8. 19 km = \_\_\_\_\_ m
  9. 29 L = \_\_\_\_\_ mL
  10. 83 m = \_\_\_\_\_ mm
  11. 1.8 cm = \_\_\_\_\_ mm
  12. 2.5 mg = \_\_\_\_\_ g
  13. 2.6 km = \_\_\_\_\_ m
  14. 8.5 km = \_\_\_\_\_ m
  15. 80 mL = \_\_\_\_\_ L
  16. 150 mm = \_\_\_\_\_ cm
  17. 5000 m = \_\_\_\_\_ km
  18. 1300 g = \_\_\_\_\_ kg
  19. 17 mm = \_\_\_\_\_ cm
  20. 125 mm = \_\_\_\_\_ cm
  21. 170 L = \_\_\_\_\_ mL
  22. 155 m = \_\_\_\_\_ km
23. A particular pipe is delivered in sections 5 meters long. How many sections are required to span a distance of 1 kilometer?
24. You need to measure 34.6 milligrams of a chemical to make a solution. If the display on the scale only shows grams, what will the reading be?

25. During your last visit to the doctor, the nurse told you that you weighed 98 kilograms. Assuming that a nickel weighs approximately 5 grams, how many nickels would it take to equal your weight? If that were true, then how much is your weight worth in nickels?
26. Your favorite coffee mug at work holds about  $\frac{1}{2}$  a liter. If you average about 8 milliliters each time you take a sip, how many sips does it take to get to the bottom of your mug?

## Answers:

- |              |               |                           |
|--------------|---------------|---------------------------|
| 1. 100 cm    | 10. 83,000 mm | 19. 1.7 cm                |
| 2. 1000 mg   | 11. 18 mm     | 20. 12.5 cm               |
| 3. 1000 g    | 12. 0.0025 g  | 21. 170,000 mL            |
| 4. 10 mm     | 13. 2600 m    | 22. 0.155 km              |
| 5. 100 mm    | 14. 8500 m    | 23. 200 sections          |
| 6. 500 mm    | 15. 0.08 L    | 24. 0.0346 g              |
| 7. 8000 m    | 16. 15 cm     | 25. 19,600 nickels, \$980 |
| 8. 19,000 m  | 17. 5 km      | 26. 62.5 sips             |
| 9. 29,000 mL | 18. 1.3 kg    |                           |

**Metric System and Temperature Conversion Practice Problems**

Convert the following:

1. 23 g into \_\_\_\_\_ mg
2. 12,456 m into \_\_\_\_\_ km
3. 4235 mL into \_\_\_\_\_ L
4. 200 mg into \_\_\_\_\_ kg
5. 1000 watts into \_\_\_\_\_ kwatts
6. 0.05 g into \_\_\_\_\_  $\mu\text{g}$
7. 20 deciliters into \_\_\_\_\_ mL
8. 140 kg into \_\_\_\_\_ g
9. 9.5 cm into \_\_\_\_\_ mm
10. 100 milliseconds into \_\_\_\_\_ seconds

Convert the following:

1. 12 C° into \_\_\_\_\_ °F
2. 80 F° into \_\_\_\_\_ °C
3. 150 F° into \_\_\_\_\_ °C
4. 100 C° into \_\_\_\_\_ °F
5. 32 F° into \_\_\_\_\_ °C

**Answers:**

1. 23,000 mg
2. 12.456 km
3. 4.235 L
4. 0.0002 kg
5. 1 kwatt
6. 50,000  $\mu\text{g}$
7. 2000 mL
8. 140,000 g
9. 95 mm
10. 0.1 seconds

**Part 2**

1. 53.6°F
2. 26.67°C
3. 65.6°C
4. 212°F
5. 0°C



## **Section 3**

# **Circumference, Area, and Volume**

# CIRCUMFERENCE AND AREA

Applied Math for Wastewater Systems

## Parts of a Circle

- Diameter is distance across the center of circle
- Radius is distance from circle's center to the edge
- Circumference is the distance around a circle or a circular object
- Pi ( $\pi$ ) is a mathematical constant
  - $\pi = 3.14159265359$

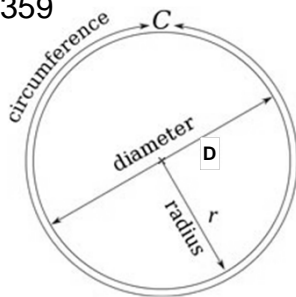

## Circumference & Perimeter

- Circumference of a Circle

$$\begin{aligned} \text{Circumference} &= (3.14)(\text{Diameter}) \quad \text{OR} \\ \text{Circumference} &= 2(\pi)(\text{radius}) \end{aligned}$$

- Perimeter is obtained by adding the lengths of the four sides of a square or rectangle

$$\text{Perimeter} = 2(\text{length}) + 2(\text{width})$$

## Example 1 & 2

- Find the circumference of a 6 inch diameter pipe.

$$\text{Circumference} = 2(\pi)(\text{radius})$$

$$C = 2(\pi)(3 \text{ inches})$$

$$C = 18.85 \text{ inches}$$

- Find the perimeter of a rectangular tank that is 15 ft by 22 ft.

$$\text{Perimeter} = 2(\text{length}) + 2(\text{width})$$

$$P = 2(15 \text{ ft}) + 2(22 \text{ ft})$$

$$P = 30 \text{ ft} + 44 \text{ ft}$$

$$P = 74 \text{ ft}$$

## Area

- Area is the measurement of the amount of space on the surface of an object
- Two dimensional measurement
- Measured in: in<sup>2</sup>, ft<sup>2</sup>, acres, etc.

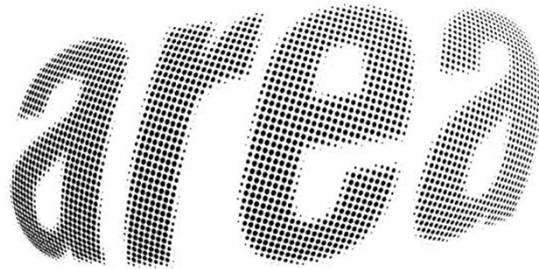

## Area

- Area of Circle

$$\text{Area} = (0.785) (\text{Diameter})^2$$

$$A = (0.785)(D)^2$$

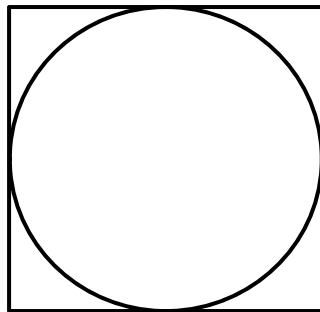

A circle takes up  
78.5% of a square.



### Example 3

- Find the area of the cross section of a pipe in  $\text{ft}^2$  that has a diameter of 2 feet.

$$\text{Area} = (0.785)(D)^2$$

$$A = (0.785)(2\text{ft})(2\text{ft})$$

$$A = 3.14 \text{ ft}^2$$

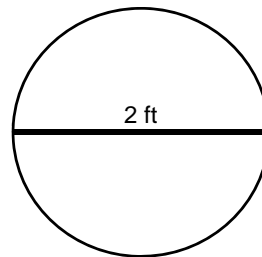

### Area

- Area of Rectangle

$$\text{Area} = (\text{length})(\text{width})$$

$$A = (L)(W)$$

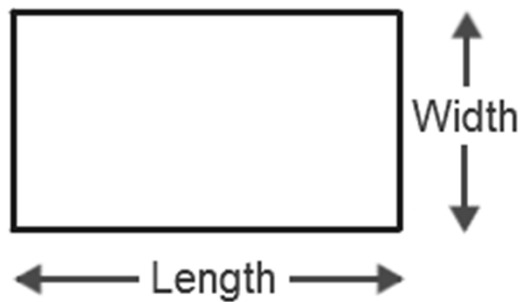

## Example 4

- Find the area in  $\text{ft}^2$  of a rectangular basin that is 20 feet long and 17 feet wide.

$$A = (L)(W)$$

$$A = (20\text{ft})(17\text{ft})$$

$$A = 340\text{ft}^2$$

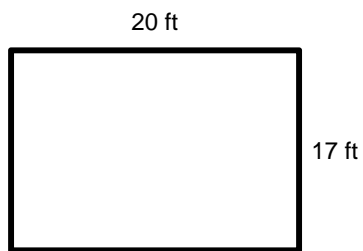

## Area

- Area of Right Triangle

$$\text{Area} = \frac{(\text{base})(\text{height})}{2}$$

$$A = \frac{(b)(h)}{2}$$

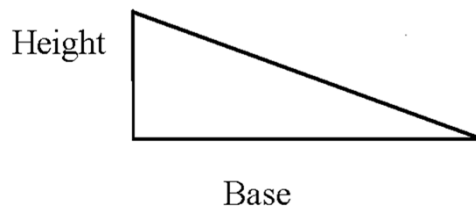

## Example 5

- Determine the area in  $\text{ft}^2$  of a right triangle where the base is 23 feet long with a height of 16 feet.

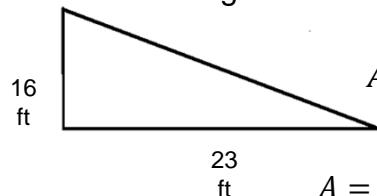

$$A = \frac{(b)(h)}{2}$$

$$A = \frac{(23\text{ft})(16\text{ft})}{2}$$

$$A = \frac{368\text{ft}^2}{2}$$

$$A = 184\text{ft}^2$$

## Area

- Area of Cylinder (total exterior surface area)

$$\begin{aligned} \text{Area} = & [\text{surface area of end \#1}] \\ & + [\text{surface area of end \#2}] \\ & + [(\pi)(\text{Diameter})(\text{height})] \end{aligned}$$

$$A = A_1 + A_2 + [(\pi)(D)(h)]$$

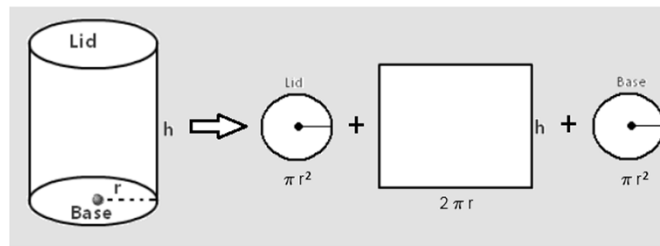

## Example 6

- Find the total surface area in  $\text{ft}^2$  of a pipeline that is 2 ft in diameter and 20 feet long.

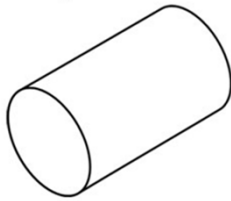

$$A = A_1 + A_2 + [(\pi)(D)(h)]$$

$$A_1 = (0.785)(D)^2$$

$$A_1 = (0.785)(2\text{ft})(2\text{ft})$$

$$A_1 = 3.1416\text{ft}^2$$

$$A_1 = A_2$$

$$A = 3.1416\text{ft}^2 + 3.1416\text{ft}^2 + [(\pi)(2\text{ft})(20\text{ft})]$$

$$A = 3.1416\text{ft}^2 + 3.1416\text{ft}^2 + 125.6637\text{ft}^2$$

$$A = 1240.26\text{ft}^2$$

## Area

- Area of Cone (lateral area)

$$\text{Area} = (\pi)(\text{radius})\sqrt{\text{radius}^2 + \text{height}^2}$$

$$A = (\pi)(r)\sqrt{r^2 + h^2}$$

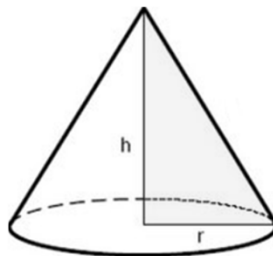

Right Circular Cone

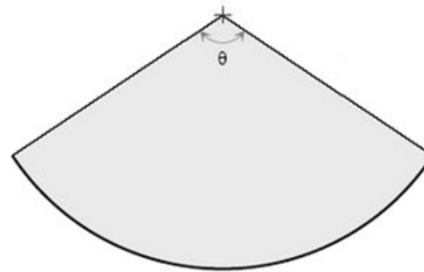

Unrolled Lateral Area

## Example 7

- Find the lateral area (in  $\text{ft}^2$ ) of a cone that is 3 feet tall and has a radius of 1.5 feet.

$$A = (\pi)(r)\sqrt{r^2 + h^2}$$

$$A = (\pi)(1.5\text{ft})\sqrt{(1.5\text{ft})^2 + (3\text{ft})^2}$$

$$A = (\pi)(1.5\text{ft})\sqrt{2.25\text{ft}^2 + 9\text{ft}^2}$$

$$A = (\pi)(1.5\text{ft})\sqrt{11.25\text{ft}^2}$$

$$A = (\pi)(1.5\text{ft})(3.3541\text{ft})$$

$$A = 15.81\text{ft}^2$$

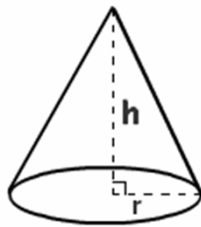

## Area

- Area of Cone (total surface area)

$$\text{Area} = (\pi)(\text{radius})(\text{radius} + \sqrt{\text{radius}^2 + \text{height}^2})$$

$$A = (\pi)(r)(r + \sqrt{r^2 + h^2})$$

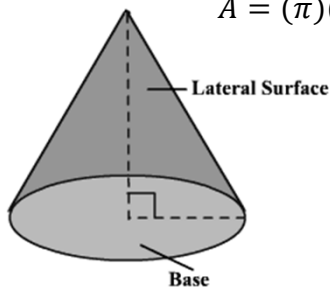

## Example 8

- Find the total surface area in  $\text{ft}^2$  of a cone that is 4.5 feet deep with a diameter of 6 feet.

$$A = (\pi)(r)(r + \sqrt{r^2 + h^2})$$

$$\text{radius} = \frac{1}{2}D$$

$$r = \left(\frac{1}{2}\right)6\text{ft}$$

$$A = (\pi)(3\text{ft})(3\text{ft} + \sqrt{(3\text{ft})^2 + (4.5\text{ft})^2}) \quad r = 3\text{ft}$$

$$A = (\pi)(3\text{ft})(3\text{ft} + \sqrt{9\text{ft}^2 + 20.25\text{ft}^2})$$

$$A = (\pi)(3\text{ft})(3\text{ft} + \sqrt{29.25\text{ft}^2})$$

$$A = (\pi)(3\text{ft})(3\text{ft} + 5.4083\text{ft})$$

$$A = (\pi)(3\text{ft})(8.4083\text{ft})$$

$$A = 79.25\text{ft}^2$$

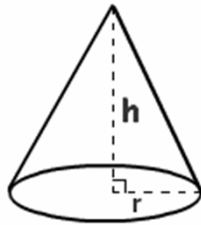

## Volume

## Volume

- Volume is the capacity of a unit or how much it will hold
- Measured in
  - cubic units ( $\text{ft}^3$ ,  $\text{m}^3$ ,  $\text{yd}^3$ ) or
  - liquid volume units (gallons, liters, million gallons)
- The answer will come out in cubic units
  - You must then convert it to liquid volume units

## Volume of a Cylinder

$$\text{Volume} = (0.785)(\text{Diameter}^2)(\text{height})$$

$$\text{Vol} = (0.785)(D^2)(h)$$

OR

$$\text{Volume} = (\pi)(\text{radius}^2)(\text{height})$$

$$\text{Vol} = (\pi)(r^2)(h)$$

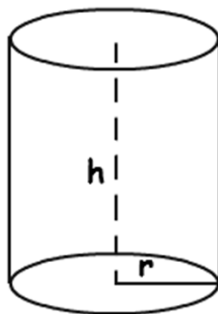

## Example 1

- Determine the volume in  $\text{ft}^3$  for a tank that is 20 feet tall with a diameter of 7.5 ft.

$$\text{Vol} = (0.785)(D)^2(h)$$

$$\text{Vol} = (0.785)(7.5\text{ft})(7.5\text{ft})(20\text{ft})$$

$$\text{Vol} = 883.13 \text{ ft}^3$$

## Volume of a Cone

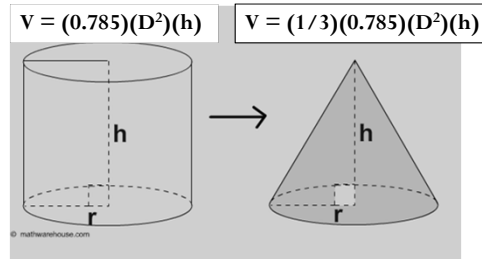

$$\text{Volume} = \left(\frac{1}{3}\right)(0.785)(\text{Diameter}^2)(\text{height})$$

$$\text{Vol} = \left(\frac{1}{3}\right)(0.785)(D^2)(h)$$

OR

$$\text{Volume} = \left(\frac{1}{3}\right)[(\pi)(\text{radius}^2)(\text{height})]$$

$$\text{Vol} = \left(\frac{1}{3}\right)[(\pi)(r^2)(h)]$$



## Example 2

- Determine the volume in gallons of a conical tank that is 8 feet wide and 15 feet tall.

$$Vol = \left(\frac{1}{3}\right)(0.785)(D^2)(h)$$

$$Vol = \left(\frac{1}{3}\right)(0.785)(8ft)(8ft)(15ft)$$

$$Vol = (0.3333)(753.6 ft^3)$$

$$Vol = 251.1749 ft^3$$

$$Vol, gal = (251.1749 ft^3) \left(7.48 \frac{gal}{ft^3}\right)$$

$$Vol, gal = 1878.78 gallons$$

## Volume of a Rectangle

$$Volume = (length)(width)(height)$$

$$Vol = (l)(w)(h)$$

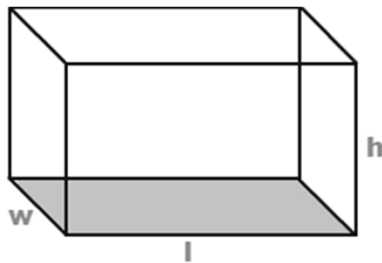

### Example 3

- Determine the volume in  $m^3$  for a tank that measures 30 meters by 15 meters by 25 meters.

$$Vol = (l)(w)(h)$$

$$Vol = (30m)(15m)(25m)$$

$$Vol = 11,250m^3$$

### Any Questions?

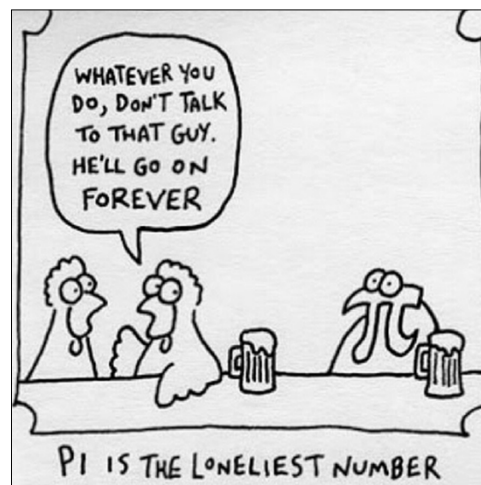

## Math Problem Strategies

Strategy for solving word problems:

- 1) Read the problem, disregard the numbers (What type of problem is it? What am I asked to find?)
- 2) Refer to the diagram, if provided. If there isn't one, draw your own.
- 3) What information do I need to solve the problem, and how is it given in the statement of the problem?
- 4) Work it out.
- 5) Does it make sense?

It might be helpful to write out everything that is known in one column and the unknown (what am I asked to find?) in another column. Identify the correct formula and write it in the middle, plug in the numbers and solve.

### Known

Length = 35 ft  
Width = 49 ft

$$A = (l)(w)$$

$$A = (35 \text{ ft})(49 \text{ ft})$$

$$A = 1715 \text{ ft}^2$$

### Unknown

Area = ?

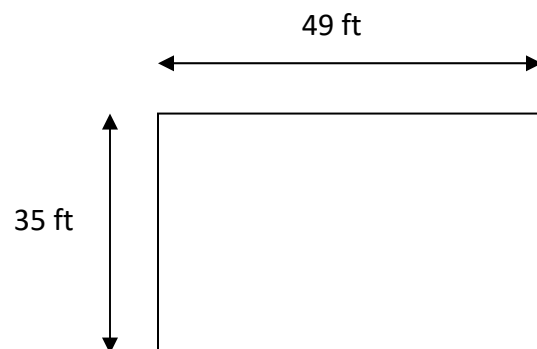

**\*\*Remember: Make sure measurements agree!**

- ***If diameter of pipe is in inches, change to feet***
- ***If flow is in MGD and you need feet or feet/sec, change to ft<sup>3</sup>/sec before you plug values into formula.***

|             |     |             |              |              |              |                |                 |                   |     |                       |
|-------------|-----|-------------|--------------|--------------|--------------|----------------|-----------------|-------------------|-----|-----------------------|
|             |     |             |              |              |              |                |                 |                   |     |                       |
| mega<br>(M) | ... | kilo<br>(k) | hecto<br>(h) | deka<br>(da) | no<br>prefix | deci<br>(d)    | centi<br>(c)    | milli<br>(m)      | ... | micro<br>(μ)          |
| 1,000,000   |     | 1,000       | 100          | 10           | 1            | $\frac{1}{10}$ | $\frac{1}{100}$ | $\frac{1}{1,000}$ |     | $\frac{1}{1,000,000}$ |

Tank Volume Calculations: Most tank volumes calculations are for tanks that are either rectangular or cylindrical in shape.

### Rectangular Tank

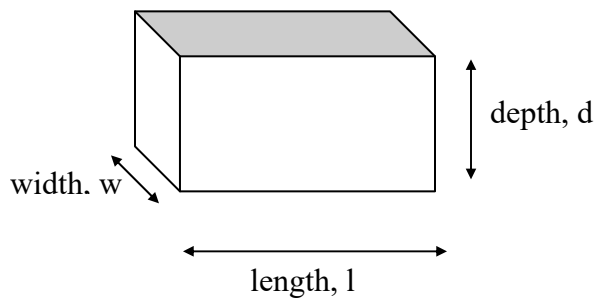

$$\text{Volume} = (l)(w)(d)$$

### Cylindrical Tank

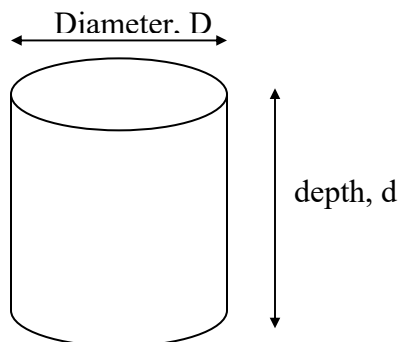

$$\text{Volume} = (0.785)(D)^2(d)$$

### Portion of a Pipeline

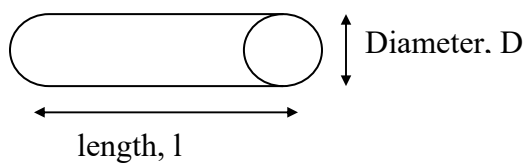

$$\text{Volume} = (0.785)(D)^2(l)$$

## Circumference, Area, and Volume Problems

### Circumference

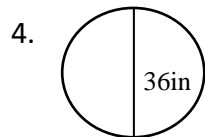
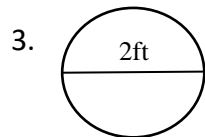
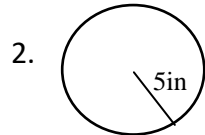
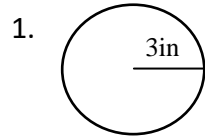

5. A chemical holding tank has a diameter of 24 feet. What is the circumference of the tank in feet?
6. An influent pipe inlet opening has a diameter of 4 feet. What is the circumference of the inlet opening in inches?
7. What is the length (in feet) of the notched weir of a circular clarifier that has a diameter of 32 feet?

Area

1. A basin has a length of 45 feet and a width of 12 feet. Calculate the area in  $\text{ft}^2$ .
2. If the diameter of a circle is 10 inches, what is the cross-sectional area in square feet?
3. Calculate the surface area (in  $\text{ft}^2$ ) of a basin which is 90 feet long, 25 feet wide, and 10 feet deep.
4. Calculate the area (in  $\text{ft}^2$ ) for a 2 ft diameter main that has just been laid.
5. What is the area of a rectangle that is 3 feet by 9 feet?
6. Calculate the area (in  $\text{ft}^2$ ) for an 18" main that has just been laid.

7. Calculate the lateral surface area (in  $\text{ft}^2$ ) of a cone with a radius of 3 feet and a height of 9 feet.
8. A chemical hopper is cone shaped and covered. It has a diameter of 4 feet and a depth of 7 feet. Calculate the total surface area of the hopper (in  $\text{ft}^2$ ).
9. A circular water tower that is tapered at the bottom has a diameter of 36 feet and a height of 52 feet from the top to the beginning of the taper. The cone created by the taper has a height of 20 feet. Calculate the total exterior surface area of the water tower.

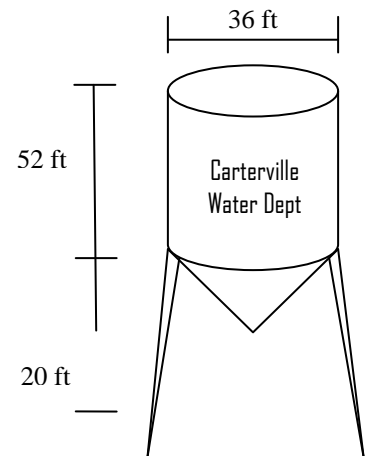

Volume

1. Calculate the volume (in  $\text{ft}^3$ ) for a tank that measures 10 feet by 10 feet by 10 feet.
2. Calculate the volume (in gallons) for a basin that measures 22 feet by 11 feet by 5 feet.
3. Calculate the volume of water in a tank (in gallons), which measures 12 feet long, 6 feet wide, 5 feet deep, and contains 8 inches of water.
4. Calculate the volume (in  $\text{ft}^3$ ) of a cone shaped chemical hopper with a diameter of 12 feet and a depth of 18 feet.
5. A new water main needs to be disinfected. The main is 30" in diameter and has a length of 0.25 miles. How many gallons of water will it hold?



6. A 3 million gallon water tank needs to be disinfected. The method you will use requires you to calculate 5% of the tank volume. How many gallons will this be?
7. Refer back to the water tower in Carterville in problem 7 of the last section. Calculate the total volume (in gallons) when the tower is full.

DON'T THINK TOO HARD ON THIS ONE...

8. If you double the size of a pipe, does it double the volume that can be carried? For example, if you have 1000 feet of 12 inch line and you replace it with a 24 inch line, does your volume double?

## Answers:

Circumference

1. 18.85 in
2. 31.42 in
3. 6.28 ft
4. 113.10 in
5. 75.40 ft
6. 150.80 in
7. 100.53 ft

Area

1. 540 ft<sup>2</sup>
2. 0.55 ft<sup>2</sup>
3. 2250 ft<sup>2</sup>
4. 3.14 ft<sup>2</sup>
5. 27 ft<sup>2</sup>
6. 1.77 ft<sup>2</sup>
7. 89.41 ft<sup>2</sup>
8. 58.31 ft<sup>2</sup>
9. 8420.51 ft<sup>2</sup>

Volume

1. 1,000 ft<sup>3</sup>
2. 9050.8 gal
3. 359.04 gal
4. 678.58 ft<sup>3</sup>
5. 48442.35 gal
6. 150,000 gal
7. 446671.14 gal
8. No, it quadruples (4x)

## **Section 4**

### **Velocity and Flow**

# Velocity & Flow

Applied Math for Wastewater Systems

## Velocity

- The speed at which something is moving
- Measured in

○  $ft/min$   $ft/sec$   $miles/hr$  etc

$$Velocity = \frac{distance}{time}$$

## Example 1

- Blue dye is placed in a sewer line at a manhole. Three (3) minutes later, the dye appears in a manhole 125 feet down stream. What is the velocity of the flow in ft/min?

$$Velocity = \frac{distance}{time}$$

$$Vel = \frac{125 \text{ ft}}{3 \text{ min}}$$

$$Vel = 41.67 \text{ ft}/\text{min}$$

## Flow

- The volume of water that flows over a period of time
- Measured in

$$\circ \text{ ft}^3/\text{sec} \quad \text{ft}^3/\text{min} \quad \text{gal}/\text{day} \quad \text{MG}/\text{D}$$

$$Flow = (Area)(Velocity)$$

$$Q = AV$$

## Example 2

- Water is flowing at velocity 3 ft/sec through a channel that is 2 feet wide and 1.5 feet deep. What is the flow in cubic feet per second?

$$Q = AV$$

$$Q = (l)(w)(velocity)$$

$$Q = (2ft)(1.5ft)(3 \text{ ft/sec})$$

$$Q = 9 \text{ ft}^3/\text{sec}$$

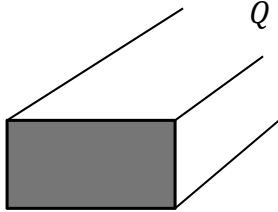

## Example 3

- Determine the flow in ft<sup>3</sup>/sec through a 6 inch pipe that is flowing full at a velocity of 4.5 ft/sec.

$$\begin{aligned} 6\text{in} \div 12 \frac{\text{in}}{\text{ft}} \\ = 0.5\text{ft} \end{aligned}$$

$$Q = AV$$

$$Area = (0.785)(D^2)$$

$$Q = (0.785)(D)^2(vel)$$

$$Q = (0.785)(0.5\text{ft})(0.5\text{ft})(4.5 \text{ ft/sec})$$

$$Q = 0.88 \text{ ft}^3/\text{sec}$$

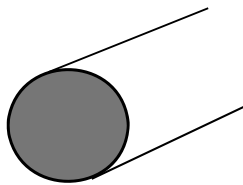

# Velocity

$$\text{Velocity} = \frac{\text{Flow rate, } ft^3/sec}{\text{Area, } ft^2}$$

- Use this formula when given the flow and area or dimensions

## Example 4

- The flow through a 1.5 foot pipeline is 9.7 gallons per minute. What is the velocity of the water in ft/minute?

$$\text{Velocity} = \frac{\text{Flow rate, } ft^3/sec}{\text{Area, } ft^2}$$

$$\frac{9.7 \frac{gal}{min}}{7.48 \frac{gal}{ft^3}}$$

$$= 1.30 \frac{ft^3}{min}$$

$$\text{Vel} = \frac{1.30 \frac{ft^3}{min}}{(0.785)(1.5ft)(1.5ft)}$$

$$\text{Area} = (0.785)(D^2)$$

$$\text{Vel} = \frac{1.30 \frac{ft^3}{min}}{1.7663 \text{ } ft^2}$$

$$\text{Vel} = 0.74 \frac{ft}{min}$$

Any Questions?



## Applied Math for Wastewater Flow Conversions

1. Express a flow of 5 cfs in terms of gpm.
2. What is 38 gps expressed as gpd?
3. Convert a flow of 4,270,000 gpd to cfm.
4. What is 5.6 MGD expressed as cfs? (round to nearest tenth)
5. Express 423,690 cfd as gpm.
6. Convert 2730 gpm to gpd.

**Answers:**

- |                      |                              |
|----------------------|------------------------------|
| 1. 2244 gpm          | 4. 8.68 ft <sup>3</sup> /sec |
| 2. 3,283,200 gal/day | 5. 2200.83 gal/min           |
| 3. 397.11 cfm        | 6. 3,931,200 gal/day         |

## Flow and Velocity Problems

### Velocity

1. A cork is placed in a channel and travels 370 feet in 2 minutes. What is the velocity of the wastewater in the channel, ft/min?
2. A float travels 300 feet in a channel in 2 minutes and 14 seconds. What is the velocity in the channel, ft/sec?
3. The distance between manhole #1 and manhole #2 is 105 feet. A fishing bobber is dropped into manhole #1 and enters manhole #2 in 30 seconds. What is the velocity of the wastewater in the sewer in ft/min?

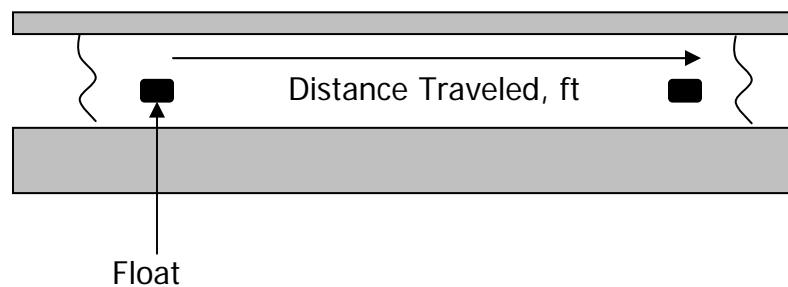

$$\text{Velocity} = \frac{\text{Distance Traveled, ft}}{\text{Duration of Test, min}}$$

$$= \text{ft/min}$$

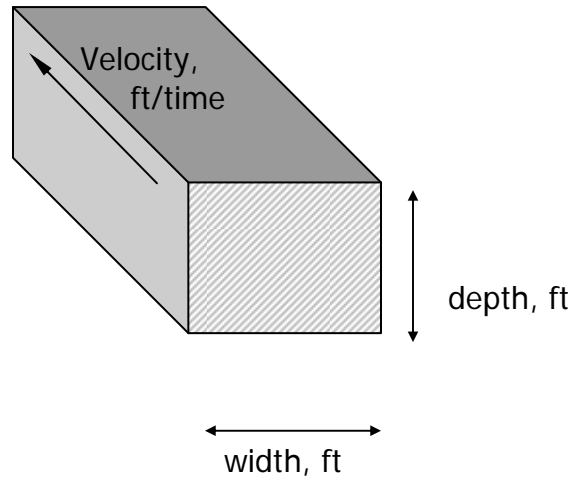

$$Q = (A)(V)$$

$\text{ft}^3/\text{time} \quad (\text{ft})(\text{ft}) \quad (\text{ft}/\text{time})$

#### Flow in a channel

4. A channel 48 inches wide has water flowing to a depth of 1.5 feet. If the velocity of the water is 2.8 ft/sec, what is the flow in the channel in cu ft/sec?
  
5. A channel 3 feet wide has water flowing to a depth of 2.5 feet. If the velocity through the channel is 120 feet/min, what is the flow rate in cu ft/min? in MGD?
  
6. A channel is 3 feet wide and has water flowing at a velocity of 1.5 ft/sec. If the flow through the channel is 8.1 ft<sup>3</sup>/sec, what is the depth of the water in the channel in feet?

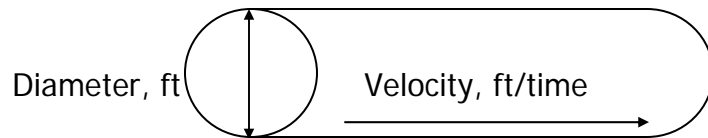

$$Q \quad = \quad (A) \quad (V)$$

$$\text{ft}^3/\text{time} \quad \quad \quad \text{ft}^2 \quad \quad \quad (\text{ft}/\text{time})$$

$$Q \quad = \quad (0.785) (D)^2 (vel)$$

$$\text{ft}^3/\text{time} \quad \quad \quad (\text{ft})(\text{ft}) \quad \quad \quad (\text{ft}/\text{time})$$

#### Flow through full pipe

7. The flow through a 2 ft diameter pipeline is moving at a velocity of 3.2 ft/sec. What is the flow rate in cu ft/sec?
  
8. The flow through a 6 inch diameter pipeline is moving at a velocity of 3 ft/sec. What is the flow rate in ft<sup>3</sup>/sec?
  
9. An 8 inch diameter pipeline has water flowing at a velocity of 3.4 ft/sec. What is the flow rate in gpm?
  
10. The flow through a pipe is 0.7 ft<sup>3</sup>/sec. If the velocity of the flow is 3.6 ft/sec, and the pipe is flowing full, what is the diameter of the pipe in inches?

## Answers:

1. 185 ft/min
2. 2.24 ft/sec
3. 210 ft/min
4.  $16.8 \text{ ft}^3/\text{sec}$
5.  $900 \text{ ft}^3/\text{min}$  and 9.69 MGD
6. 1.8 ft
7.  $10.05 \text{ ft}^3/\text{sec}$
8.  $0.59 \text{ ft}^3/\text{sec}$
9. 534.07 gpm
10. 5.97 in

### More Velocity and Flow Problems

1. A float travels 500 ft in a channel in 5 minutes and 22 seconds. What is the velocity in ft/sec?
2. A cork is placed in a channel and travels 50 ft in 9 seconds, what is the velocity in ft/ min?
3. A car travels at a speed of 60 mph, what is the velocity in ft/sec?
4. The distance between a manhole A and manhole B is 400 ft. A float is dropped into manhole A and enters manhole B in 2 minutes and 30 seconds. What is the velocity of the water in ft/min?
5. A garden snail travelled 15 inches in 10 minutes, what is the snail's velocity in ft/min?



10. A channel is 24 inches wide and has water to a depth of 18 inches. If the water is flowing at a velocity of 2.9 ft/sec, what is the flow rate in cubic feet/min?
11. The flow through a channel is 100 gpm. If the channel is 3 ft wide and has water to a depth of 2 ft, what is the velocity of the water in ft/sec?
12. The flow through a 3 ft diameter pipeline is moving at a velocity of 4 ft/sec. What is the flow through the pipe in cubic feet/sec?
13. The flow through a 10 inch diameter pipe is moving at a velocity of 2 ft/sec. What is the flow rate in cubic ft/sec?



14. A 6 inch diameter pipe has water flowing at a velocity of 120 ft/min. What is the flow rate in gpm?
15. The flow through a pipe is  $0.82 \text{ ft}^3/\text{sec}$ . If the velocity of the flow is 1.5 ft/sec, and the pipe is flowing full, what is the diameter of the pipe in inches?
16. A 2 ft main has water flowing at a velocity of 4.1 ft /sec. What is the flow through the pipe in gph?
17. A 3 ft diameter force main has just been installed. According to the Design Criteria for the State of Tennessee, at pumping capacity, a minimum self-scouring velocity of 3 ft/sec should be maintained. If the main is flushed at a velocity of 5 ft/sec, how many gallons per minute will be flushed from the line?

18. A pipe has a diameter of 24 inches. If the pipe is flowing full, and the water is known to flow a distance of 200 ft in 3 minutes, what is the flow rate for the pipe in MGD?
19. What is the flow rate in gpd for a 6 inch main flowing at a velocity of 220 ft/min?
20. If the flow through a 10 inch diameter pipe is 3.2 MGD, what is the velocity of the water in ft /sec?
21. The flow through a pipe is 320 gpm. If the velocity through the pipe is 3.6 ft/sec what is the diameter of the pipe in inches?
22. A certain pipe has a diameter of 10 inches. If the water in the pipe is known to travel 200 yds in 3 minutes, what is the flow rate for the pipe in gpd?

**More Velocity and Flow Problems Answers**

1. 1.55 ft/sec
2. 333.3 ft/min
3. 88 ft/sec
4. 160 ft/min
5. 0.125 ft/min
6. 8.83 ft<sup>3</sup>/sec
7. 12.5 ft<sup>3</sup>/sec
8. 0.853 ft
9. 2,356 gpm
10. 522 ft<sup>3</sup>/min
11. 0.037 ft/sec
12. 28.3 ft<sup>3</sup>/sec
13. 1.089 ft<sup>3</sup>/sec
14. 176 gpm
15. 10 in
16. 346,671 gph
17. 15,853.86 gpm
18. 2.25 MGD
19. 443,908 gpd
20. 9.09 ft sec
21. 6 in
22. 1,173,420 gpd



**Section 5**

**Collections & Preliminary**

**Treatment**

Applied Math for  
Wastewater Systems

# PRELIMINARY TREATMENT CALCULATIONS

## Preliminary Treatment

- ⦿ Initial stage of treatment
- ⦿ Headworks – Raw influent entering plant
- ⦿ Protects downstream plant equipment by removing trash and debris
  - Clogs, jams, excessive wear on plant machinery
  - Saves valuable space within the plant



## Preliminary Treatment

- ⦿ **Screening**
- ⦿ **Shredding**
- ⦿ **Grit Removal**
- ⦿ **Pre-Aeration**
- ⦿ **Odor Control**
- ⦿ **Septage Handling**
- ⦿ **Flow Measurement**
- ⦿ **Flow Equalization**

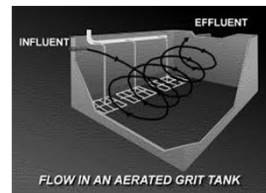

## Preliminary Treatment

1. Screening
  - Removing large solids, rags, cans, rocks, branches, etc. from the influent flow
2. Grit Removal
  - Removing inorganic solids (sand, gravel, clay, egg shells, coffee grounds, etc.) that could cause excessive mechanical wear

## Screening

- ◎ Screenings Removal Calculations
  - Operators may be required to keep a record of the amount of screenings removed
  - In order to properly plan for screenings disposal, it is important to keep a record of the amount of screenings removed

## Screenings Removed

- ◎ Screenings Removed =  $\frac{\text{Screenings, ft}^3}{\text{Days}}$
- ◎ Screenings Removed =  $\frac{\text{Screenings, ft}^3}{\text{Flow, MG}}$





## Screenings Removed

- ◎ *Example:* A total of 65 gallons of screenings are removed from the wastewater flow during a 24-hour period. What is the screening removal reported as cubic feet per day (cu ft/day or ft<sup>3</sup>)?

1. Convert gallon screenings to cu ft.:

$$\frac{65 \text{ gal}}{1} \times \frac{1 \text{ ft}^3}{7.48 \text{ gal}} = 8.7 \text{ ft}^3 \text{ screenings}$$

2. Calculate screenings removed as ft<sup>3</sup>/day:

$$\text{Screenings removed, cu ft/day} = \frac{8.7 \text{ ft}^3}{1 \text{ day}} = 8.7 \text{ ft}^3/\text{day}$$

## Screenings Pit Capacity

- ◎ Screenings pit capacity calculations are actually detention time calculations.
  - Reminder: Detention time is the time required to flow through a tank or *the time required to fill a tank or basin at a given flow rate*
- ◎ In these problems, the time required to fill a screening pit is calculated.

## Screenings Pit Capacity

- Fill time =  $\frac{\text{Volume of Tank, gal}}{\text{Flow Rate, gal/time}}$
- Screenings Pit Fill Time, days =  $\frac{\text{Volume of Pit, ft}^3}{\text{Screenings Removed, ft}^3/\text{day}}$



## Screenings Pit Capacity

- *Example:* A plant has been averaging a screenings removal of 2 ft<sup>3</sup>/MG. If the average daily flow is 1.6 MGD, how many days will it take to fill the pit with an available capacity of 150 ft<sup>3</sup>?

1. Convert filling rate to cu ft/day:

$$\frac{2 \text{ ft}^3}{1 \text{ MG}} \times \frac{1.6 \text{ MG}}{1 \text{ day}} = 3.2 \text{ ft}^3/\text{day}$$

2. Calculate fill time:

$$\text{Fill time, days} = \frac{150 \text{ ft}^3}{3.2 \text{ ft}^3/\text{day}} = 46.9 \text{ days}$$

## Grit Removal

- ◎ Wastewater systems typically average 1 – 15 ft<sup>3</sup> of grit per million gallons of flow, with higher ranges during storm events
  - Sanitary: 1-4 ft<sup>3</sup>/MG
  - Combined: 4-15 ft<sup>3</sup>/MG
- ◎ Generally, grit is disposed of in sanitary landfills or burial, so for planning purposes, operators must keep accurate records of grit removal.



## Grit Removal

- ◎ Grit Removed, ft<sup>3</sup>/MG =  $\frac{\text{Grit Volume, ft}^3}{\text{Flow, MG}}$

### *Forecasting Disposal Needs*

- ◎ Over a given time, the average grit removal rate (ex: a seasonal average) can be determined and used for planning purposes. Often grit removal is calculated in cubic yards, since excavation is normally expressed in terms of cubic yards.

$$\frac{\text{Total grit, ft}^3}{27 \text{ ft}^3/\text{yd}^3} = \text{yd}^3 \text{ grit}$$

## Grit Removal

- ◎ *Example 1:* A treatment plant removes 10 ft<sup>3</sup> of grit in 1 day. How many ft<sup>3</sup> of grit are removed per million gallons if the plant flow is 9 MGD?

$$\text{Grit removed, ft}^3/\text{MG} = \frac{10 \text{ ft}^3}{9 \text{ MG}} = 1.1 \text{ ft}^3/\text{MG}$$

## Grit Removal

- ◎ *Example 2:* The average grit removal at a plant is 2.1 ft<sup>3</sup>/MG. If the monthly average daily flow is 4.5 MGD, how many yd<sup>3</sup> of grit would be removed from the wastewater flow during one month (30 days)?

1. Calculate cu ft grit removed from average daily flow:

$$\frac{2.1 \text{ ft}^3}{1 \text{ MG}} \times \frac{4.5 \text{ MG}}{1 \text{ day}} = 9.45 \text{ ft}^3/\text{day}$$

2. Calculate anticipated grit removed for the month:

$$\frac{9.45 \text{ ft}^3}{1 \text{ day}} \times \frac{30 \text{ days}}{1} = 283.5 \text{ ft}^3$$

3. Convert cu ft grit removed to yd<sup>3</sup> grit:

$$\frac{283.5 \text{ ft}^3}{1} \times \frac{1 \text{ yd}^3}{27 \text{ ft}^3} = 10.5 \text{ yd}^3$$

## Grit Channel Velocity

- ⦿ Flow in the grit channel is decreased to about 1 fps to permit settling of heavy inorganic solids.
- ⦿ These problems can be solved using
  - Float and stopwatch method
  - Flow and channel dimensions
  - (Refer back to those sections)

## Population Equivalent (Organic)

- ⦿ A means of expressing the strength of organic material in wastewater.
- ⦿ Population Equivalents:
  - 1 person = 0.17 lbs BOD/day
  - 1 person = 0.22 lbs SS/day
  - 1 person = 0.14 lbs VS/day
- ⦿ Population Equivalent, Organic =
 
$$\frac{(\text{Flow, MGD})(\text{BOD, } \frac{\text{mg}}{\text{L}})(8.34 \frac{\text{lbs}}{\text{gal}})}{0.17 \text{ lb} \frac{\text{BOD}}{\text{day}} / \text{person}}$$
- ⦿ “How many people are represented by \_\_\_\_ pounds of BOD?”

## Population Equivalent

- *Example:* A plant receives a raw sewage flow of 3.1 MGD with a BOD concentration of 220 mg/L. What is the population equivalent of this wastewater?

- Population Equivalent, Organic = 
$$\frac{(\text{Flow, MGD})(\text{BOD, } \frac{\text{mg}}{\text{L}})(8.34 \frac{\text{lbs}}{\text{gal}})}{0.17 \text{ lb } \frac{\text{BOD}}{\text{day}}/\text{person}}$$

- = 
$$\frac{(3.1 \text{ MGD})(220 \text{ mg/L})(8.34 \frac{\text{lbs}}{\text{gal}})}{0.17 \text{ lb } \frac{\text{BOD}}{\text{day}}/\text{person}}$$

- = 
$$\frac{5,687.9 \text{ lbs BOD/day}}{0.17 \text{ lb } \frac{\text{BOD}}{\text{day}}/\text{person}}$$

- = 33,458 people

- “How many people are represented by 5,687.9 lbs BOD per day?”  
Answer: 33,458 people

Any Questions?



## Reference

- *Applied Math for Wastewater Plant Operators* by Joanne Kirkpatrick Price

## Applied Math for Wastewater Treatment Preliminary Treatment Math

### Wet Well Capacity

1. A wet well is 13 feet long, 8 feet wide and 10 feet deep. What is the gallon capacity of the wet well?

### Wet Well Pumping Rate, gpm

2. A wet well is 12 feet by 10 feet. With no influent to the well, a pump lowers the water level 1.2 feet during a 4-minute pumping test. What is the pumping rate, gpm?

### Screenings Removed

3. A total of 55 gallons of screenings are removed from the wastewater flow during a 24-hour period. What is the screenings removal, cu.ft./day?
  
  
  
  
  
  
  
  
  
  
4. The flow at a treatment plant is 3.6 MGD. If the total of 55 cu.ft. screenings are removed during a 24-hour period, what is the screenings removal, cu.ft./MG?



**Screenings Pit Capacity**

5. A screening pit has a capacity of 400 cu.ft. If an average of 3.8 cu.ft of screenings are removed daily from the wastewater flow, in how many days will the pit be full?
  
  
  
  
  
  
  
  
  
  
6. A wastewater treatment plant has an average flow of two million gallons per day. An average of 30 gallons of screenings is removed each day. Screenings are buried in a pit that will hold 15 cubic yards of screenings in addition to 6 inches of soil used to cover the screenings. How many days will the site last?

**Grit Removal, cu.ft./MG**

7. A treatment plant removes 12 cu.ft. of grit in one day. How many cu.ft./MG of grit are removed if the plant flow was 8 MGD?

**Grit Channel Velocity**

8. It takes a float 30 seconds to travel 37 feet in a grit channel. What is the velocity of the flow in the channel?

9. A wastewater plant has 2 grit channels, each channel is 3 ft. wide and has a water depth of 1.3 ft. What is the velocity when the influent flow rate is 4.0 MGD?

### **Grit Channel Flow Rate**

10. A grit channel 36 inches wide has water flowing to a depth of 1 ft. If the velocity of the wastewater is 1.1 ft/sec, what is the flow in the channel in cfs and gpm?

### **Answers:**

1. 7779.2 gal
2. 269.28 gal/min
3. 7.35 ft<sup>3</sup>/day
4. 15.28 ft<sup>3</sup>/MG
5. 105.26 days
6. 101 days
7. 1.5 ft<sup>3</sup>/MG
8. 1.23 ft/sec
9. 0.79 fps
10. 1481.04 gal/min

**Applied Math for Wastewater Treatment  
Preliminary Treatment Math - Additional Problems**

**Wet Well Capacity**

1. If the gallon capacity of a wet well is 2154 gallons, and the diameter is 6 ft, what is the maximum depth of water (in feet) in the wet well?
  
  
  
  
  
  
  
  
  
  
2. The maximum capacity of a wet well is 4787 gal. If the wet well is 10 feet long and 8 feet wide, what is the maximum depth of water in the wet well in feet?
  
  
  
  
  
  
  
  
  
  
3. A wet well is 8 ft. long, 6 ft. wide, and 6 ft. deep. What is the gallon capacity of the wet well?
  
  
  
  
  
  
  
  
  
  
4. A wet well 9 ft. long and 10 ft. wide contains wastewater to a depth of 3.7 ft. How many gallons of wastewater are in the wet well?

**Wet Well Pumping Rate, gpm**

5. A tank 50 feet in diameter is filled with water to a depth of 4 feet. To conduct a pumping test, the outlet valve to the tank is closed and the pump is allowed to discharge into the tank. After 80 minutes, the water level is 5.5 feet. What is the pumping rate in gallons per minute?

6. A wet well is 8 ft. by 10 ft. During a 2 minute pumping test (with no influent to the wet well), the water level dropped 5 inches. What is the gpm pumping rate?
  
7. During a pumping test, the water level dropped 36 inches in a wet well 11 ft. by 9 ft. The pumping rate was calculated to be 400 gpm. How long did the pumping test last (in minutes)?
  
8. The water level in a well drops 18 inches during a 3-minute pumping test. If the wet well is 8 feet by 6 feet, what is the pumping rate in gpm?
  
9. During a 15 minute pumping test, 16,400 gallons were pumped into an equalization basin. What is the pumping rate in gallons per minute?
  
10. The meter on the discharge side of the pump reads in hundreds of gallons. If the meter shows a reading of 110 at 2:00 pm and 320 at 2:30 pm, what is the pumping rate expressed in gallons per minute?

11. The depth of wastewater in a wet well is sufficiently low to allow shutting off all pumps. With a rod and a stopwatch, you are able to determine that the water level rises 1.5 ft. in 2 minutes, 30 seconds. The pumps are restarted. What is the gpm influent rate to the 8 ft. long, 8 ft. wide wet well?

### **Screenings Removed**

12. A plant received a flow of 4.4 million gallons on Tuesday, November 7. That day's screenings were calculated to be 11 ft<sup>3</sup>. How many ft<sup>3</sup> of screenings were removed per MG of flow?
13. During 1 week, a total of 310 gallons of screenings were removed from wastewater screens. What is the average removal in ft<sup>3</sup>/day?
14. The flow at a wastewater treatment plant is 3,850,000 gpd. If 80 gallons of screenings are removed between 12:00 am and 11:59 pm on October 29, what is the screenings removal expressed as ft<sup>3</sup>/MG for that day?

**Screening Pit Capacity**

15. A screenings pit has a capacity of 600 cu. ft. If an average of 2.9 cu. ft. of screenings is removed daily from the wastewater flow, in how many days will the pit be full?
16. A screenings pit has a capacity of 9 cu. yards available for screenings. If the plant removes an average of 1.6 cu.ft. per day, in how many days will the pit be full?
17. A plant has been averaging a screenings removal of 2.6 cu.ft./MG. If the average daily flow is 2.9 MGD, how many days will it take to fill a screenings pit with an available capacity of 292 cu.ft.?
18. Suppose we want to use a screenings pit for 120 days. If the screenings removal rate is 3.5 cu.ft./day, what is the required screenings pit capacity in cu.ft.?
19. A plant averages a screenings removal of 2.1 cu.ft./MG. If the average daily flow is 2.7 MGD, how many days will it take to fill a 290 cu.ft. screening pit?

20. Suppose you want to have a screenings pit capacity of 90 days (not including dirt for cover). If the screenings removal rate is  $4 \text{ ft}^3/\text{day}$ , what will the available volume of the screenings pit have to be (in  $\text{ft}^3$ )?

### **Grit Removal**

21. A treatment plant removes 12 cu.ft. of grit in a day. If the plant flow is 8 MGD, what is the grit removal expressed in cu.ft./MG?
22. The total daily grit removal for a plant is 260 gallons. If the plant flow is 11.4 MGD, how many cu.ft. of grit are removed per million gallons of flow?
23. The average grit removal at a particular treatment plant is 3.1 cu.ft./MG. If the monthly average daily flow is 3.8 MGD, how many cubic yards of grit would be removed from the wastewater flow during one 30-day month?
24. The monthly average grit removal is 2.2 cubic feet per million gallons. If the monthly average flow is 4,230,000 gpd, how many cubic yards must be available for grit disposal if the disposal pit is to have a 90-day capacity?

25. The total daily grit removal for a plant is 270 gallons. If the flow is 12.3 MGD, find the grit removal, cu.ft./MG.
26. The total daily grit removed from a plant is 250 gallons. If the plant flow is 12.2 MGD, how many  $\text{ft}^3$  of grit are removed per MG flow?
27. The monthly average grit removal is  $2.7 \text{ ft}^3/\text{MG}$ . If the monthly average flow is 3,300,000 gpd, how many  $\text{yd}^3$  must be available for grit disposal if the disposal pit is to have a 90 day capacity?

### **Grit Channel Velocity**

28. A grit channel is 4 ft. wide, with water flowing to a depth of 18 inches. If the flow meter indicates a flow rate of 1820 gpm, what is the velocity of flow through the channel in feet/sec?
29. A stick in a grit channel travels 26 feet in 32 seconds. What is the estimated velocity in the channel in feet/sec.?



30. The total flow through both channels of a grit channel is 4.3 cfs. If each channel is 3 ft wide and water is flowing to a depth of 14 inches, what is the velocity of flow through the channel in fps?
31. A stick placed in a grit channel flows 36 feet in 32 seconds. What is the estimated velocity in the channel in feet/sec.?
32. The depth of water in a grit channel is 16 inches. The channel is 34 inches wide. If the flow meter indicates a flow of 1140 gpm, what is the velocity of flow through the channel in ft/sec.?
33. A grit channel is 4.2 ft. wide, with water flowing to a depth of 12 inches. If the flow meter indicates a flow rate of 1475 gpm, what is the velocity of flow through the channel (in fps)?
34. A stick placed in a grit channel flows 19 ft. in 15 seconds. What is the estimated velocity in the channel (ft/sec)?

35. Assume you want to calculate the velocity in the grit channel at your plant's peak flow. Examining the flow charts, you determine that peak flows are usually about 3.75 MGD. The grit channel is 3 ft. wide, and the flow depth is 17 inches at peak flow. What is the velocity in the grit channel under these conditions?

### **Grit Channel Flow Rate**

36. A grit channel is 2.6 feet wide and has water flowing to a depth of 16 inches. If the velocity through the channel is 1.1 feet per second, what is the flow rate through the channel in cu.ft./sec.?
37. A grit channel 3-ft wide has water flowing at a velocity of 1.4 ft per second. If the depth of the water is 14 inches, what is the flow rate through the channel, in gal/day?
38. A grit channel 32 inches wide has water flowing to a depth of 10 inches. If the velocity of the water is 0.90 fps, what is the flow rate in the channel in cu.ft./sec?

39. A grit channel is 3 feet wide, 50 feet long with water flowing to a depth of 18 inches. What is the fpm velocity through the channel if the flow is 220 gpm?
40. A grit channel 2 ft. wide has water flowing at a velocity of 0.9 fps. If the depth of the water is 1.25 ft., what is the gpd flow rate through the channel? Assume the flow is steady and continuous.)
41. A grit channel 3 ft. wide with water flowing at a depth of 2.5 ft. has a calculated flow measurement of 2,423,520 gpd. If the flow is steady and continuous, what is the velocity of the water (in fps)?

**Answers:**

- |                              |                              |                               |
|------------------------------|------------------------------|-------------------------------|
| 1. 10.19 ft                  | 15. 206.89 days              | 29. 0.81 ft/sec               |
| 2. 8 ft                      | 16. 151.89 days              | 30. 1.23 ft/sec               |
| 3. 2154.24 gal               | 17. 38.73 days               | 31. 1.13 ft/sec               |
| 4. 2490.84 gal               | 18. 420 ft <sup>3</sup>      | 32. 0.67 ft/sec               |
| 5. 275.24 gal/min            | 19. 51.15 days               | 33. 0.78 ft/sec               |
| 6. 124.68 gal/min            | 20. 360 ft <sup>3</sup>      | 34. 1.27 ft/sec               |
| 7. 5.55 min                  | 21. 1.5 ft <sup>3</sup> /MG  | 35. 1.37 ft/sec               |
| 8. 179.52 gal/min            | 22. 3.05 ft <sup>3</sup> /MG | 36. 3.82 ft <sup>3</sup> /sec |
| 9. 1093.33 gal/min           | 23. 13.09 yd <sup>3</sup>    | 37. 3,166,797 gal/day         |
| 10. 700 gal/min              | 24. 31.02 yd <sup>3</sup>    | 38. 2.0 ft <sup>3</sup> /sec  |
| 11. 287.23 gal/min           | 25. 2.93 ft <sup>3</sup> /MG | 39. 6.54 ft/min               |
| 12. 2.5 ft <sup>3</sup> /MG  | 26. 2.74 ft <sup>3</sup> /MG | 40. 1,454,112 gal/day         |
| 13. 5.9 ft <sup>3</sup> /day | 27. 29.7 yd <sup>3</sup>     | 41. 0.5 ft/sec                |
| 14. 2.78 ft <sup>3</sup> /MG | 28. 0.68 ft/sec              |                               |



## **Section 6**

### **Chemical Dosage**

# “Pounds” Formulas and Chemical Dosage

APPLIED MATH FOR WASTEWATER SYSTEMS

Why is this important?

- Operators often need to know how many pounds of something they are dealing with:
  - Loading on a treatment system
  - Calculating pounds of a chemical to feed
  - Calculating pounds of something that is being discharged

## The “Pounds Formula”

- Converting from Metric (mg/L) into English (lbs)
- Lab results
  - Ex: BOD results (mg/L)
- Chemical concentrations
  - Ex: Phosphate Standard 50 mg/L as PO<sub>4</sub>
- Chemical dosages
  - Chlorine dose of 4.0 mg/L

## Pounds Formula

- You must know 3 things in order to calculate the amount of pounds
  1. The **quantity** of water
    - Flow or Volume, MGD or MG
  2. The **concentration** of material in the water
    - Concentration (mg/L)
    - \*Dose can be substituted for Concentration\*
  3. The **weight** of a gallon of water
    - 1 gallon of water = 8.34 pounds

## Pounds Formula

$$\text{Pounds} = (\text{Concentration})(\text{Flow or Vol})(8.34)$$

- Flow and volume must be expressed in specific units

## The Quantity of Water

- Flow ( or volume) must be expressed as MGD or MG
  - MGD = Million gallons per day
  - MG = Million gallons

A tank contains 1,125,000 gallons of water. How many million gallons are there?

$$\frac{1,125,000 \text{ gal}}{1,000,000 \text{ gal/MG}} = 1.125 \text{ MG}$$



### Concentration of Material

- Concentration must be expressed as mg/L or ppm
- mg/L = ppm

$$\frac{1 \text{ mg}}{\text{liter}} = \frac{\text{MG}}{\text{day}} = \frac{8.34 \text{ lbs}}{\text{gal}} = \text{ppm}$$

Therefore...

$$\text{mg/L} = \text{ppm} = \frac{\text{Parts}}{\text{Million}} = \frac{\text{Lbs}}{\text{Million Lbs}}$$

### Pounds

- When Volume is expressed as **MG** and Concentration is expressed as **mg/L**, the units will cancel out to leave only **pounds**.

$$\frac{\text{Lbs}}{\cancel{\text{M Lbs}}} \times \cancel{\text{MG}} \times \frac{\text{Lbs}}{\text{gal}} = \text{Lbs}$$

### Pounds/Day

- When Flow is expressed as **MGD** and Concentration is expressed as **mg/L**, the units will cancel out to leave only **pounds/day**.

$$\frac{\text{Lbs}}{\cancel{\text{M Lbs}}} \times \frac{\cancel{\text{MG}}}{\text{Day}} \times \frac{\text{Lbs}}{\cancel{\text{gal}}} = \text{Lbs/Day}$$

### Just remember...

If you insert the proper units (**mg/L**, **MG**, or **MGD**) into the equation ...you'll get results in **pounds** or **pounds/day**

### Example

- Lab results for MLSS = 3000 mg/L
- How many pounds of Mixed Liquor Suspended Solids are in the aeration basin if the basin volume is 2 million gallons?

$$(\text{Conc, mg/L})(\text{Volume, MG})\left(8.34 \frac{\text{lb}}{\text{gal}}\right) = \text{pounds}$$

$$(3000 \text{ mg/L})(2 \text{ MG})\left(8.34 \frac{\text{lbs}}{\text{gal}}\right) = 50,040 \text{ pounds MLSS}$$

### Example

- Lab results for TSS = 25 mg/L
- How many pounds of Total Suspended Solids are being discharged to the receiving stream if your flow is 10 MGD?

$$(\text{Conc, mg/L})(\text{Flow, MGD})\left(8.34 \frac{\text{lb}}{\text{gal}}\right) = \text{pounds/day}$$

$$(25 \text{ mg/L})(10 \text{ MGD})\left(8.34 \frac{\text{lbs}}{\text{gal}}\right) = 2085 \text{ pounds/day of TSS}$$

### The pounds formula can be rearranged

- What volume can be discharged to meet a pounds limit?

$$\text{MGD} = \frac{\text{Lbs}}{8.34 \frac{\text{lbs}}{\text{gal}} \times \text{conc (mg/L)}}$$

- What is the concentration if this many pounds of chemical was added?

$$\text{Conc (mg/L)} = \frac{\text{Lbs}}{8.34 \frac{\text{lbs}}{\text{gal}} \times \text{MG}}$$

### The Pounds formula is widely used in WW treatment

- Solids in Aerator, lbs = (Aerator Vol, MG)(MLSS, mg/L)(8.34  $\frac{\text{lbs}}{\text{gal}}$ )
- Lime required, lbs = (Sludge vol, MG)(Volatile Acids, mg/L)(8.34  $\frac{\text{lbs}}{\text{gal}}$ )
- BOD Loading, lbs/day = (Flow, MGD)(BOD, mg/L)(8.34  $\frac{\text{lbs}}{\text{gal}}$ )
- Solids Added, lbs/day = (Flow, MGD)(PE SS, mg/L)(8.34  $\frac{\text{lbs}}{\text{gal}}$ )
- Suspended Solids Removed, lbs/day = (Flow, MGD)(SS Removed, mg/L)(8.34  $\frac{\text{lbs}}{\text{gal}}$ )
- Etc...

### 3 names for the Pounds Formulas

#### 1. Mass

$$\text{Mass, lbs} = (\text{Conc, mg/L})(\text{Vol, MG})\left(8.34\frac{\text{lbs}}{\text{gal}}\right)$$

#### 2. Loading Rate

$$\text{Loading Rate, } \frac{\text{lbs}}{\text{day}} = (\text{Conc, mg/L})(\text{Flow, MGD})\left(8.34\frac{\text{lbs}}{\text{gal}}\right)$$

#### 3. Feed Rate

$$\text{Feed Rate, } \frac{\text{lbs}}{\text{day}} = \frac{(\text{Dose, mg/L})(\text{Flow, MGD})\left(8.34\frac{\text{lbs}}{\text{gal}}\right)}{\% \text{purity}}$$

### Chemical Application

- Different chemicals are added to locations of wastewater system to maintain the system
- The amount of chemicals needed is determined by dosage level desired and the purity of the chemicals used
  - If the purity of the chemical is not mentioned then it is assumed to be 100% available or 1.0 in decimal form for use in formulas

## Chemical Application

- Chlorine application is achieved by applying one of two types of hypochlorite
  - Sodium hypochlorite
    - ✦ NaOCl
    - ✦ Bleach
    - ✦ 5-15% concentration
  - Calcium hypochlorite
    - ✦  $\text{Ca}(\text{OCl})_2$
    - ✦ High test hypochlorite (HTH)
    - ✦ 65% concentration

## Chlorine Dose

- Dose, mg/L = Demand, mg/L + Residual, mg/L
- The chlorine **Demand** is the amount of chlorine used up in various reactions with other components of the water
  - ✦ Bacteria, ammonia, hydrogen sulfide, etc.
  - ✦ When the chlorine demand has been satisfied, these reactions stop.
- In some cases (ex: pretreatment), chlorinating just to meet demand is sufficient. However, sometimes you must have additional chlorine in the water that is available for disinfection. This extra chlorine is the **Residual**.

## Feed Rate

- When dosing a volume of wastewater, a measured amount of chemical is required

$$\text{Feed rate, } \frac{\text{lb}}{\text{day}} = \frac{(\text{Dose})(\text{Flow})(8.34 \text{ lb/gal})}{\% \text{ purity}}$$

- This is the only pounds formula that factors in the purity.

## Example 1

- A collections system wants to feed calcium hypochlorite with a purity of 65%. The required dose is 8 mg/L for a flow of 3 MGD. How many pounds per day of disinfectant must be fed?

$$\text{Feed rate, } \frac{\text{lb}}{\text{day}} = \frac{(\text{dose})(\text{flow})(8.34 \text{ lb/gal})}{\% \text{ purity}}$$

$$\begin{aligned} \frac{\text{lb}}{\text{day}} &= \frac{(8 \text{ mg/L})(3 \text{ MGD})(8.34 \text{ lb/gal})}{0.65} \\ \frac{\text{lb}}{\text{day}} &= 307.94 \text{ lb/day} \end{aligned}$$

## Mass and Loading Rate

- Same as Feed rate but without the % purity
  - If percent purity of a chemical is not provided, it is assumed to be 100% pure

$$\text{Mass, lbs} = (\text{Volume, MG}) \left( \text{conc., } \frac{\text{mg}}{\text{L}} \right) \left( 8.34 \frac{\text{lb}}{\text{gal}} \right)$$

$$\text{Loading Rate, } \frac{\text{lb}}{\text{day}} = (\text{Flow, MGD}) \left( \text{conc., } \frac{\text{mg}}{\text{L}} \right) \left( 8.34 \frac{\text{lb}}{\text{gal}} \right)$$

## Dose

- To determine dose, we will need to rearrange the feed rate or mass formula

$$\frac{\text{lb}}{\text{day}} = \frac{(\text{dose})(\text{flow}) \left( 8.34 \frac{\text{lbs}}{\text{gal}} \right)}{\% \text{ purity}}$$

$$(\% \text{ purity}) \left( \frac{\text{lb}}{\text{day}} \right) = (\text{dose})(\text{flow}) \left( 8.34 \frac{\text{lbs}}{\text{gal}} \right)$$

$$\frac{(\% \text{ purity}) \left( \frac{\text{lb}}{\text{day}} \right)}{(\text{flow}) \left( 8.34 \frac{\text{lbs}}{\text{gal}} \right)} = \text{Dose}$$



## Example 2

- A collection system feeds 65 lb/day of 65% calcium hypochlorite. If the flow is 1.6 MGD, what dose, in mg/L, of disinfectant will result?

$$\text{Dose} = \frac{(\% \text{ purity})(\frac{\text{lb}}{\text{day}})}{(\text{flow})(8.34 \text{ lb/gal})}$$

$$\text{Dose} = \frac{(0.65)(65 \text{ lb/day})}{(1.6 \text{ MGD})(8.34 \text{ lb/gal})}$$

$$\text{Dose} = 3.17 \text{ mg/L}$$

## Two Normal equation

- N = normality
  - Can be replaced with Concentration
  - Only  $C_1 \times V_1 = C_2 \times V_2$  is in the newest ABC Formula book
- V = volume or flow

$$N_1 \times V_1 = N_2 \times V_2$$

OR

$$C_1 \times V_1 = C_2 \times V_2$$

## Two Normal equation

$$C_1 \times V_1 = C_2 \times V_2$$

What you are starting with  
 or  
 What you have on hand

What you want to make  
 or  
 What you want to end up with

## Example

- An operator needs to make 10 gallons of a bleach dilution with a concentration 25 mg/L. The bleach on hand has a concentration of 100 mg/L. How many gallons of the concentrate must be used to achieve the dilution?

$$C_1 \times V_1 = C_2 \times V_2$$

$$(100 \text{ mg/L})(V) = (25 \text{ mg/L})(10 \text{ gal})$$

$$V = \frac{(25 \text{ mg/L})(10 \text{ gal})}{100 \text{ mg/L}}$$

$$V = 2.5 \text{ gal}$$

Any Questions?



## Applied Math for Wastewater Treatment Chemical Dosage

### Chemical Feed Rate (Full Strength), lbs/day

1. Determine the chlorinator setting (lbs/day) needed to treat a flow of 8.2 MGD with a chlorine dose of 4.5 mg/L.
  
  
  
  
  
  
  
  
  
  
2. The desired dosage for a dry polymer is 2.3 mg/L. If the flow to be treated is 4,236,800 gpd, how many lbs/day of polymer is required?

### Chemical Feed Rate (Less than Full Strength), lbs/day

3. A total chlorine dose of 6.8 mg/L is required to treat a particular wastewater. If the flow is 1.3 MGD and the calcium hypochlorite has 65% available chlorine, calculate the lbs/day of hypochlorite required.
  
  
  
  
  
  
  
  
  
  
4. Your town has been receiving complaints about odors in your sewer system. To correct the problem, you have decided to feed calcium hypochlorite (65% available chlorine). The recommended dose is 15 mg/L chlorine. If your flow is 69 gpm, how much calcium hypochlorite is required, lbs/day?

**Chlorine Dose, Demand and Residual, mg/L**

Remember:

Dose = Demand + Residual

The formula can be rearranged into:

Demand = Dose – Residual or Residual = Dose – Demand

5. A secondary wastewater effluent is tested and found to have a chlorine demand of 3.2 mg/L. If the desired chlorine residual is 0.5 mg/L, what is the desired chlorine dose, mg/L?
  
  
  
  
  
  
  
  
  
  
6. What should the chlorinator setting be (lbs/day) to treat a flow of 4.2 MGD if the chlorine demand is 6 mg/L and a chlorine residual of 1.0 mg/L is desired?

**Chemical Dosage, mg/L**

7. A wastewater plant has a flow of 1,180 gpm. If the chlorinator is feeding 76 pounds per day, what is the dose in mg/L?
  
  
  
  
  
  
  
  
  
  
8. The chlorinator is set to feed 26.5 lbs of chlorine per 24 hours for a plant flow of 1.2 MGD. Calculate the chlorine residual for a chlorine demand of 1.85 mg/L.

**Hypochlorination**

9. How many pounds of HTH (65% available chlorine) will it take to make a 5% solution when dissolved in enough water to make 25 gallons of hypochlorite?
10. How many pounds of 65% HTH are used to make 10 gallon of 5% solution?

**Answers:**

1. 307.75 lbs/day
2. 81.27 lbs/day
3. 113.42 lbs/day
4. 19.13 lbs/day
5. 3.7 mg/L
6. 245.20 lbs/day
7. 5.36 mg/L
8. 0.80 mg/L
9. 16.01 lbs
10. 6.42 lbs



5. To control hydrogen sulfide ( $H_2S$ ) and odors in an 8-inch sewer, the chlorine dose must be 10 mg/L when the flow is 0.37 MGD. Determine the chlorine feed rate in lbs/day.
  
6. A wastewater flow of 3.8 cfs requires a chlorine dose of 15 mg/L. What is the desired chlorine feed rate in lbs/day?
  
7. A company contends a new product effectively controls roots in sewer pipes at a concentration of 150 mg/L if the contact time is 60 minutes. How many pounds of chemical are required, assuming perfect mixing, if 450 feet of 6-inch sewer were to be treated?
  
8. Some chemical solution feeders dispense chemical as milliliters per minute (mL/min). If the desired solution feed rate was calculated to be 8 gpd, what is this feed rate expressed as mL/min?



**Chemical Feed Rate (Less than Full Strength), lbs/day**

9. A total chlorine dose of 10.8 mg/L is required to treat a particular wastewater. If the flow is 2.77 MGD and the calcium hypochlorite has 65% available chlorine, calculate the lbs/day of hypochlorite required.
  
  
  
  
  
  
  
  
  
  
10. The desired dose of a polymer is 4 mg/L. The polymer literature provided indicates the compound is 60% active polymer. If a flow of 4.2 MGD is to be treated, how many lbs/day of polymer compound must be fed?
  
  
  
  
  
  
  
  
  
  
11. The effluent from a wastewater lagoon requires a chlorine dose of 18 mg/L. If the average daily flow is 1,095,000 gpd and sodium hypochlorite (15% available chlorine) is to be used to disinfect the wastewater, how many lbs/day of hypochlorite are required?
  
  
  
  
  
  
  
  
  
  
12. If sodium hypochlorite (15% available chlorine) is used instead in #10, how many gallons must be fed daily? (Assume 1 gallon of solution weighs 8.34 lbs.)

13. Your town has been receiving complaints about odors in your sewer system. To correct the problem, you have decided to feed calcium hypochlorite (65% available chlorine). The recommended dose is 15 mg/L chlorine. If your flow is 75 gpm, how much calcium hypochlorite is required, lbs/day?
14. To inactivate and control slime in the collection system, 40% sodium hydroxide (NaOH) can be fed at about 8,000 mg/L over one hour. If the NaOH solution is used to treat a section of 12-inch sewer 800 ft long, calculate the volume in gallons of NaOH solution required. (Assume 1 gallon solution weighs 8.34 lbs)
15. A wastewater flow of 840,000 gpd requires a chlorine dose of 20 mg/L. If sodium hypochlorite (15% available) is to be used, how many lbs/day of NaOCl are required? How many gal/day of NaOCl is this?

### **Chlorine Dose, Demand and Residual, mg/L**

16. A secondary wastewater effluent is tested and found to have a chlorine demand of 4.8 mg/L. If the desired chlorine residual is 0.9 mg/L, what is the desired chlorine dose, mg/L?

17. The chlorine dose for a secondary effluent is 8.4 mg/L. If the chlorine residual after a 30 minute contact time is found to be 0.8 mg/L, what is the chlorine demand, mg/L?
  
  
  
  
  
  
  
  
  
  
  
  
  
  
  
  
  
  
  
  
  
  
18. What should the chlorinator setting be (lbs/day) to treat a flow of 3.9 MGD if the chlorine demand is 8 mg/L and a chlorine residual of 1.5 mg/L is desired?
  
  
  
  
  
  
  
  
  
  
  
  
  
  
  
  
  
  
  
  
  
  
19. A secondary effluent is tested and found to have a chlorine demand of 4.9 mg/L. If the desired residual is 0.8 mg/L, what is the desired chlorine dose (mg/L)?
  
  
  
  
  
  
  
  
  
  
  
  
  
  
  
  
  
  
  
  
  
  
20. The chlorine dosage for a secondary effluent is 8.8 mg/L. If the chlorine residual after 30 minutes of contact time is found to be 0.9 mg/L, what is the chlorine demand in mg/L?
  
  
  
  
  
  
  
  
  
  
  
  
  
  
  
  
  
  
  
  
  
  
21. The chlorine demand of a secondary effluent is 7.9 mg/L. If the chlorine residual of 0.6 mg/L is desired, what is the desired chlorine dosage in mg/L?

22. What should the chlorinator setting be (lbs/day) to treat a flow of 5.1 MGD if the chlorine demand is 4 mg/L and a chlorine residual of 3 mg/L is desired?

**Chemical Dosage, mg/L**

23. The chlorinator is set to feed 31.5 lbs of chlorine per 24 hours for a plant flow of 1.6 MGD. Calculate the chlorine residual for a chlorine demand of 1.85 mg/L.
24. A wastewater plant has a flow of 2,570 gpm. If the chlorinator is feeding 93 pounds per day, what is the dose in mg/L?
25. What should the chlorinator setting be in lbs/day to treat a flow of 4.0 MGD if the chlorinator demand is 9 mg/L and a chlorine residual of 1.7 mg/L is desired?
26. The chlorine demand for a secondary effluent is 7.8 mg/L. If a 0.3 mg/L residual is desired, how many pounds of chlorine should be dosed to a flowrate of 5.7 MGD?

**Hypochlorination**

27. How many pounds of HTH (65% available chlorine) will it take to make a 2% solution when dissolved in enough water to make 15 gallons of hypochlorite?
28. How many pounds of 65% HTH are used to make 1 gallon of 3% solution?
29. How many pounds of 65% available HTH is needed to make 5 gallons of 18% solution?
30. You need to make 10 gallons of a 9% hypochlorite solution. You have 65% HTH on hand, how many pounds of HTH will you need?

**Use the following information for problems 31 - 34:**

At 8:00 a.m. on Monday morning a chlorine cylinder weighs 83 pounds. At 8:00 a.m. on Tuesday morning the same cylinder weighs 69 pounds.

31. What is the chlorinator feed rate in pounds per day?

32. Estimate the chlorine dose in mg/L for the chlorinator. The flow totalizer reads 12,982,083 gallons at 8:00AM on Monday morning and 13,528,924 at 8:00AM on Tuesday morning. (Note: This totalizer does not zero out each morning.)
33. If the setting on the chlorinator does not change, how many pounds of chlorine will be left in the cylinder on Friday morning at 8:00 a.m.?
34. How many 150-lb chlorine cylinders will this water plant need in a month (with 30 days) if the chlorinator setting remains the same?

**Use the following information for problems 35 - 37:**

At 8:00 a.m. on Friday morning a chlorine cylinder weighs 298 pounds. That afternoon at 4:00 p.m. the same cylinder weighs 216 pounds.

35. What is the chlorinator feed rate in pounds per day?
36. How many pounds of chlorine will be in the cylinder at 8:00 a.m. on Saturday morning if the feed rate does not change?

37. What is the minimum number of ton cylinders the operator will need in a month with 31 days (at this feed rate)?

**Average Use Calculations**

38. The amount of chemical used each day for a week is given below. Based on the data, what was the average chemical use (in lbs/day) during the week?
- Monday 92 lbs/day
  - Tuesday 94 lbs/day
  - Wednesday 92 lbs/day
  - Thursday 88 lbs/day
  - Friday 96 lbs/day
  - Saturday 92 lbs/day
  - Sunday 88 lbs/day
39. If chlorine costs 15 cents per pound, what is the daily cost to chlorinate 5 MGD of wastewater to an initial concentration of 2.6 mg/L?
40. The average chemical use at a plant is 83 lb/day. If the chemical inventory in stock is 2600 lbs, how many days' supply is this?

**Answers:**

1. 117.43 lbs/day
2. 125.1 lbs/day
3. 15.23 lbs/day
4. 3415.23 lbs
5. 30.86 lbs/day
6. 307.10 lbs/day
7. 0.83 lbs
8. 21.03 mL/min
9. 383.85 lbs/day
10. 233.52 lbs/day
11. 1095.876 lbs/day
12. 10.80 gal/day
13. 20.79 lbs/day
14. 94 gal
15. 112 gal/day
16. 5.7 mg/L
17. 7.6 mg/L
18. 309 lbs/day
19. 5.7 mg/L
20. 7.9 mg/L
21. 8.5 mg/L
22. 297.74 lbs/day
23. 0.51 mg/L
24. 3.01 mg/L
25. 356.95 lbs/day
26. 385.06 lbs/day
27. 3.84 lbs
28. 0.42 lbs
29. 11.51 lbs
30. 11.51 lbs
31. 14 lbs/day
32. 3.07 mg/L
33. 27 lbs
34. 3 (150-lb) cylinders
35. 246 lbs/day
36. 52 lbs
37. 4 (2000-lb or 1 ton) cylinders
38. 91.7 lbs/day
39. \$16.26/day
40. 31.33 days



## **Section 7**

### **Sedimentation**

# Sedimentation

Applied Math for Wastewater Plant Operators  
Joanne Kirkpatrick Price

## DETENTION TIME

*Detention Time is Flow-Through Time*

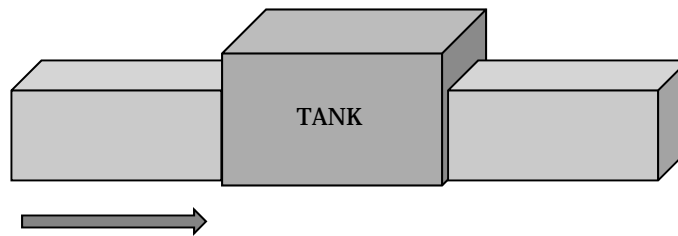

$$\text{Detention Time, hrs} = \frac{\text{Volume of Tank, gal}}{\text{Flow, gph}}$$

The equation includes arrows indicating unit relationships: a solid arrow points from the denominator "Flow, gph" to the numerator "Volume of Tank, gal", and a dashed arrow points from the denominator "Flow, gph" to the unit "hrs" in the numerator.

**Be sure your time and volume units match!**

## DETENTION TIME

### **Example 1**

The flow to a sedimentation tank 60 ft long, 30 ft wide, and 10 ft deep is 2.45 MGD. What is the detention time in the tank, in hours?

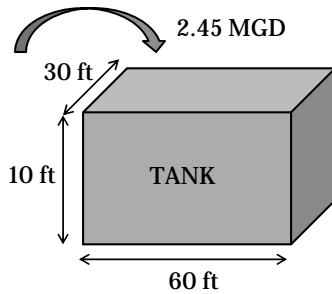

Tank Volume:

Volume (ft<sup>3</sup>) = (L,ft)(W,ft)(d,ft)

Vol. = (60ft)(30ft)(10ft) = 18000 ft<sup>3</sup>

Vol. = (18000 ft<sup>3</sup>)(7.48 gal/ft<sup>3</sup>) = 134640 gal

Flow Rate:

Flow = MGD → gph

= (2.45 MG/day)(1 day/24 hrs)(1000000 gal/1 MG)

= 102083.3333 gph

$$\text{Detention Time, hrs} = \frac{\text{Volume of Tank, gal}}{\text{Flow, gph}}$$

## DETENTION TIME

$$\text{Detention Time, hrs} = \frac{\text{Volume of Tank, gal}}{\text{Flow Rate, gph}}$$

$$= \frac{134640 \text{ gal}}{102083.3333 \text{ gph}}$$

$$= 1.32 \text{ hrs}$$

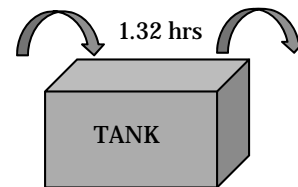

## WEIR OVERFLOW RATE

- Weir overflow rate (WOR) is a measure of the gallons per day flowing over each foot of weir
- WOR calculations are important in detecting high velocities near the weir which affect the efficiency of the sedimentation process
- With excessively high velocities near the weir, the settling solids are pulled over the weirs and into the effluent troughs, thus preventing desired settling

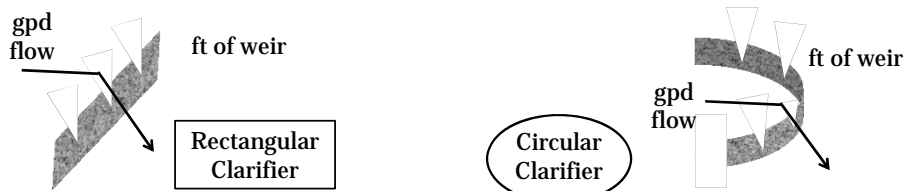

## WEIR OVERFLOW RATE

- If you are not given a total weir length in a problem then you must calculate it
- The shape of the clarifier will need to be known to calculate either a perimeter or a circumference

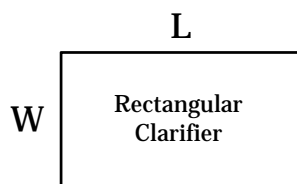

$$\text{Perimeter} = 2(L) + 2(W)$$

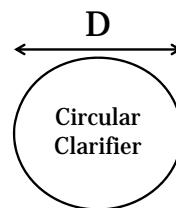

$$\text{Circumference} = (3.14)(\text{Diameter})$$

## WEIR OVERFLOW RATE

$$\text{Weir Overflow Rate, gpd/ft} = \frac{\text{Flow, gpd}}{\text{Weir Length, ft}}$$

Weir Overflow Rate is commonly expressed in gpd/ft

## WEIR OVERFLOW RATE

### **Example 1**

A rectangular clarifier has a total of 130 ft. of weir. What is the weir overflow rate in gpd/ft when the flow is 1,200,000 gpd?

Rectangular Clarifier

$$\begin{aligned} \text{Weir Overflow Rate, gpd/ft} &= \frac{\text{Flow, gpd}}{\text{Weir Length, ft}} \\ &= \frac{1,200,000 \text{ gpd}}{130 \text{ ft}} \\ &= 9230.77 \text{ gpd/ft} \end{aligned}$$

## WEIR OVERFLOW RATE

### Example 2

A rectangular clarifier has a length of 60 ft and a width of 45 ft. What is the weir overflow rate in gpd/ft when the flow is 2.71 MGD?

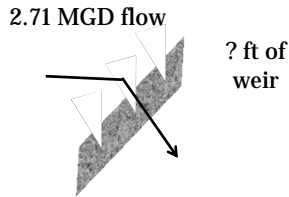
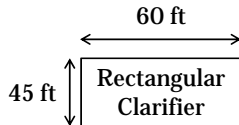

#### Flow Rate:

$$\begin{aligned} \text{Flow} &= \text{MGD} \rightarrow \text{gpd} \\ &= (2.71 \text{ MG/Day}) (1000000 \text{ gal/1 MG}) \\ &= 2710000 \text{ gpd} \end{aligned}$$

#### Weir Length:

$$\begin{aligned} \text{Perimeter} &= 2(L) + 2(W) \\ &= 2(60\text{ft}) + 2(45\text{ft}) = 120\text{ft} + 90\text{ft} \\ &= 210\text{ft} \end{aligned}$$

$$\text{Weir Overflow Rate, gpd/ft} = \frac{\text{Flow, gpd}}{\text{Weir Length, ft}}$$

## WEIR OVERFLOW RATE

### Example 2

A rectangular clarifier has a length of 60 ft and a width of 45 ft. What is the weir overflow rate in gpd/ft when the flow is 2.71 MGD?

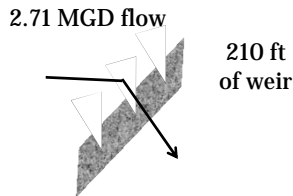

$$\text{Weir Overflow Rate, gpd/ft} = \frac{\text{Flow, gpd}}{\text{Weir Length, ft}}$$

$$= \frac{2,710,000 \text{ gpd}}{210 \text{ ft}}$$

$$= 12904.76 \text{ gpd/ft}$$

## SURFACE OVERFLOW RATE

- Surface overflow rate (SOR) (also called Surface Loading Rate) is a measure of the gallons per day overflowing the process per square foot of clarifier
- Flow per unit area
- SOR differs from Hydraulic Loading Rate which measures total water entering the process (plant flow plus recirculation), SOR measures only plant flow

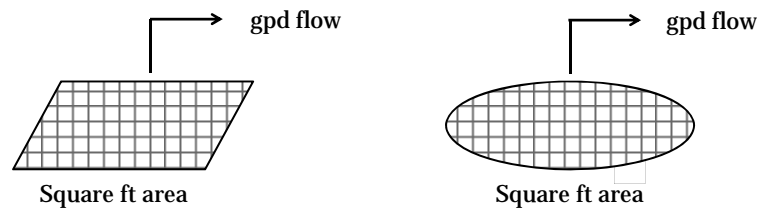

## SURFACE OVERFLOW RATE

- SOR calculations do not include recirculated flows because they are taken from the bottom of the clarifier and hence do not flow up and out of the clarifier (overflow)
- Since SOR is a measure of flow divided by area, it is an indirect measure of the upward velocity of water as it overflows the clarifier
- This calculation is important in maintaining proper clarifier operation since settling solids will be drawn upward and out of the clarifier if SOR are too high



## SURFACE OVERFLOW RATE

$$\text{Surface Overflow Rate, gpd/ft} = \frac{\text{Flow, gpd}}{\text{Area, ft}^2}$$

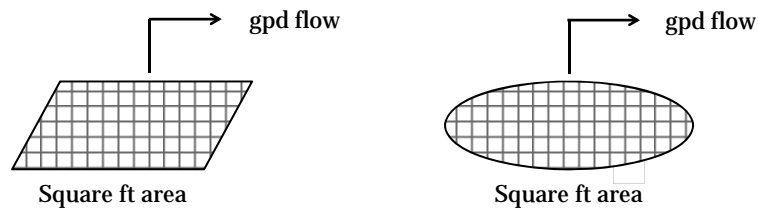

## SURFACE OVERFLOW RATE

### **Example 1**

A circular clarifier has a diameter of 58 ft. What is the surface overflow rate in gpd/ft<sup>2</sup> if the primary effluent flow is 2.93 cfs?

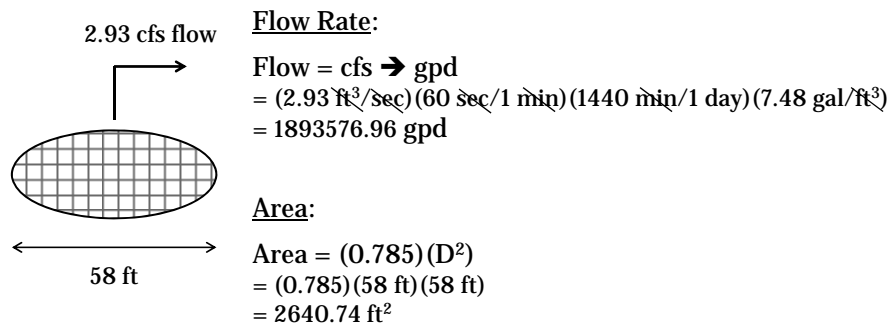

$$\text{Surface Overflow Rate, gpd/ft}^2 = \frac{\text{Flow, gpd}}{\text{Area, ft}^2}$$



## SURFACE OVERFLOW RATE

### **Example 1**

A circular clarifier has a diameter of 58 ft. What is the surface overflow rate in gpd/ft<sup>2</sup> if the primary effluent flow is 2.93 cfs?

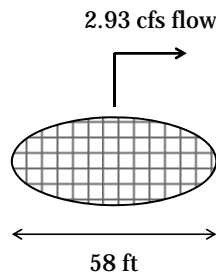

$$\text{Surface Overflow Rate, gpd/ft}^2 = \frac{\text{Flow, gpd}}{\text{Area, ft}^2}$$

$$= \frac{1,893,576.96 \text{ gpd}}{2640.74 \text{ ft}^2}$$

$$= 717.06 \text{ gpd/ft}^2$$



## SOLIDS LOADING RATE

- Solids loading rate (SLR) is calculated to determine the solids loading on activated sludge secondary clarifiers and gravity sludge thickeners
- SLR indicates the lbs/day solids loaded to each square foot of clarifier surface area
- The majority of solids coming into the secondary clarifier come in as mixed liquor suspended solids (MLSS) from the aeration tank

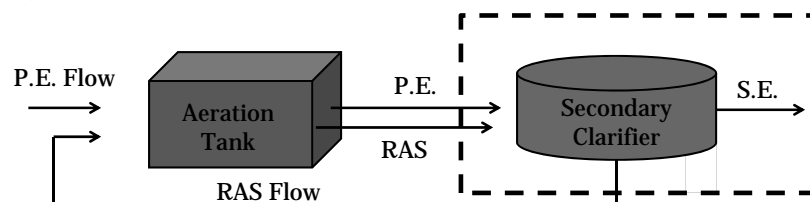

## SOLIDS LOADING RATE

$$\text{Solids Loading Rate, lbs/day/ft}^2 = \frac{\text{Solids Applied, lbs/day}}{\text{Surface Area, ft}^2}$$

Expanded form:

$$\text{SLR, lbs/day/ft}^2 = \frac{\left(\text{MLSS, } \frac{\text{mg}}{\text{L}}\right) (\text{Flow, MGD}) \left(8.34 \frac{\text{lbs}}{\text{gal}}\right)}{\text{Surface Area, ft}^2}$$

## SOLIDS LOADING RATE

### **Example 1**

A secondary clarifier is 75 ft in diameter and receives a combined primary effluent (P.E.) and return activated sludge (RAS) flow of 4.5 MGD. If the MLSS concentration in the aeration tank is 2900 mg/L, what is the solids loading rate on the secondary clarifier in lbs/day/ft<sup>2</sup>?

4.5 MGD flow Solids Applied:

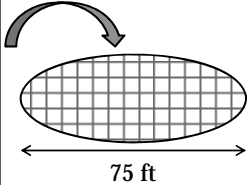

$$\begin{aligned} \text{Loading Rate (lbs/day)} &= (\text{MLSS, mg/L})(Q, \text{MGD})(8.34 \text{ lbs/gal}) \\ &= (2900 \text{ mg/L})(4.5 \text{ MGD})(8.34 \text{ lbs/gal}) \\ &= 108837 \text{ lbs/day} \end{aligned}$$

Area:

$$\begin{aligned} \text{Area} &= (0.785)(D^2) \\ &= (0.785)(75 \text{ ft})(75 \text{ ft}) \\ &= 4415.625 \text{ ft}^2 \end{aligned}$$

$$\text{Solids Loading Rate, lbs/day/ft}^2 = \frac{\text{Solids Applied, lbs/day}}{\text{Surface Area, ft}^2}$$

## SOLIDS LOADING RATE

### **Example 1**

A secondary clarifier is 75 ft in diameter and receives a combined primary effluent (P.E.) and return activated sludge (RAS) flow of 4.5 MGD. If the MLSS concentration in the aeration tank is 2900 mg/L, what is the solids loading rate on the secondary clarifier in lbs/day/ft<sup>2</sup>?

4.5 MGD flow

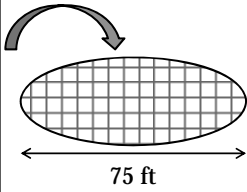

$$\text{Solids Loading Rate, lbs/day/ft}^2 = \frac{\text{Solids Applied, lbs/day}}{\text{Surface Area, ft}^2}$$

$$= \frac{108837 \text{ lbs/day}}{4415.625 \text{ ft}^2}$$

$$= 151.78 \text{ lbs/day/ft}^2$$

## BOD and Suspended Solids Removed, lbs/day

- To calculate the pounds of BOD or suspended solids removed each day, you need to know the mg/L BOD or SS removed and the plant flow in MGD
- If not given in the problem you must calculate the BOD or SS removal by using the influent concentration (what is entering the system) and the effluent concentration (how much is still in the wastewater leaving the system)

$$\begin{array}{r} \text{Influent} \\ \text{BOD or SS} \\ \text{mg/L} \end{array} - \begin{array}{r} \text{Effluent} \\ \text{BOD or SS} \\ \text{mg/L} \end{array} = \begin{array}{r} \text{Removed} \\ \text{BOD or SS} \\ \text{mg/L} \end{array} \boxed{\phantom{000}}$$

## BOD and Suspended Solids Removed, lbs/day

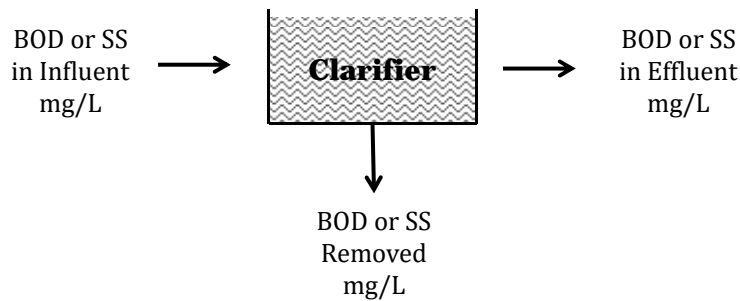

- Once you have determined the mg/L BOD or SS removed you can use the pounds formula (loading rate) to calculate the amount removal in lbs/day

## BOD and Suspended Solids Removed, lbs/day

### **Example 1**

The flow to a secondary clarifier is 2.1 MGD. If the influent BOD concentration is 205 mg/L and the effluent BOD concentration is 82 mg/L, how many pounds of BOD are removed daily?

BOD Removed, mg/L:

$$\text{Influent BOD (mg/L)} - \text{Effluent BOD (mg/L)} = \text{BOD Removed (mg/L)}$$

$$= (205 \text{ mg/L}) - (82 \text{ mg/L}) = 123 \text{ mg/L}$$

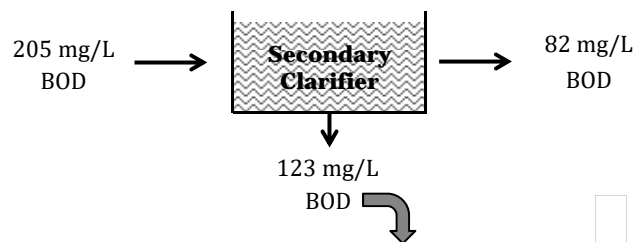

$$\text{BOD Removed, lbs/day} = (\text{BOD Removed, mg/L})(\text{Flow, MGD})(8.34 \text{ lbs/gal})$$

## BOD and Suspended Solids Removed, lbs/day

### **Example 1**

The flow to a secondary clarifier is 2.1 MGD. If the influent BOD concentration is 205 mg/L and the effluent BOD concentration is 82 mg/L, how many pounds of BOD are removed daily?

$$\text{BOD Removed, lbs/day} = (\text{BOD Removed, mg/L})(\text{Flow, MGD})(8.34 \text{ lbs/gal})$$

$$= (123 \text{ mg/L})(2.1 \text{ MGD})(8.34 \text{ lbs/gal})$$

$$= 2154.22 \text{ lbs/day}$$

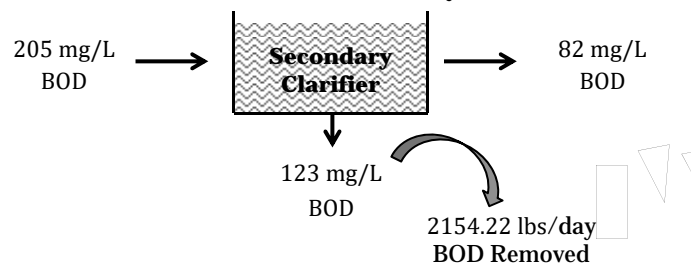

## Unit Process Efficiency, %

- The efficiency of a treatment process is its effectiveness in removing various constituents from the wastewater
- SS and BOD removal are common calculations of unit process efficiency

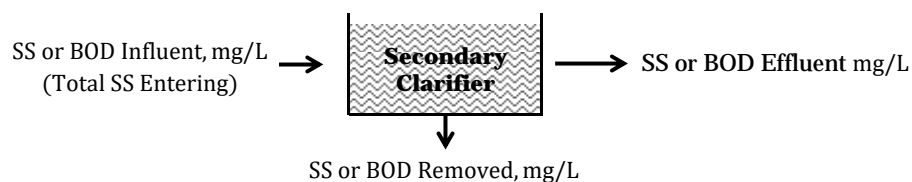

*Unit Process Efficiency is Percent Removal*

## Unit Process Efficiency, %

$$\% \text{ Removed, (SS or BOD)} = \frac{\text{SS or BOD Removed, mg/L}}{\text{SS or BOD Total, mg/L}} \times 100$$

*Unit Process Efficiency is Percent Removal*



## Unit Process Efficiency, %

### **Example 1**

The suspended solids entering a primary clarifier is 175 mg/L. If the suspended solids in the primary clarifier effluent is 61 mg/L, what is the suspended solids removal efficiency of the primary clarifier?

SS Removed, mg/L:

$$\begin{aligned} \text{Influent SS (mg/L)} - \text{Effluent SS (mg/L)} &= \text{SS Removed (mg/L)} \\ = (175 \text{ mg/L}) - (61 \text{ mg/L}) &= 114 \text{ mg/L} \end{aligned}$$

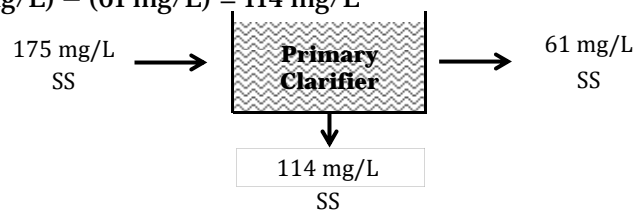

$$\% \text{ Removed, (SS or BOD)} = \frac{\text{SS or BOD Removed, mg/L}}{\text{SS or BOD Total, mg/L}} \times 100$$

## Unit Process Efficiency, %

### **Example 1**

The suspended solids entering a primary clarifier is 175 mg/L. If the suspended solids in the primary clarifier effluent is 61 mg/L, what is the suspended solids removal efficiency of the primary clarifier?

$$\% \text{ Removed, (SS)} = \frac{SS \text{ Removed, mg/L}}{SS \text{ Total, mg/L}} \times 100$$

$$= \frac{114 \cancel{\text{ mg/L}}}{175 \cancel{\text{ mg/L}}} \times 100$$

$$= 65.14\%$$



Any Questions?

## Applied Math for Wastewater Treatment Sedimentation

### Detention Time, hours

1. The flow to a circular clarifier is 3,940,000 gpd. If the clarifier is 75 ft in diameter and 12 feet deep, what is the clarifier detention time in hours?
  
  
  
  
  
  
  
  
  
  
2. The flow to a sedimentation tank 80 feet long, 30 feet wide and 14 feet deep is 4.05 MGD. What is the detention time in the tank, in hours?

### Weir Overflow Rate, gpd/ft

3. A rectangular clarifier has a total of 210 ft. of weir. What is the weir overflow rate in gpd/ft when the flow 3,728,000 gpd?
  
  
  
  
  
  
  
  
  
  
4. A circular clarifier receives a flow of 3.6 MGD. If the diameter of the weir is 80 feet, what is the WOR in gpd/ft.?



**Surface Overflow Rate, gpd/sq.ft.**

5. A circular clarifier has a diameter of 50 feet. If the primary clarifier influent flow is 2,260,000 gpd, what is the surface overflow rate in gpd/sq.ft.?
  
  
  
  
  
  
  
  
  
  
6. A sedimentation basin 90 feet long and 25 feet wide receives a flow of 2,180,400 gpd. What is the SOR in gpd/sq. ft.?

**Solids Loading Rate, lbs/day/sq.ft.**

7. A secondary clarifier, 55-ft in diameter, receives a primary effluent flow of 1,887,000 gpd and a return sludge flow of 528,000 gpd. If the MLSS concentration is 2640 mg/L, what is the solids loading rate in lbs/day/sq.ft. on the clarifier?
  
  
  
  
  
  
  
  
  
  
8. A secondary clarifier, 70 feet in diameter, receives a primary effluent flow of 2,740,000 gpd and a return sludge flow of 790,000 gpd. If the mixed liquor suspended solids concentration is 2815 mg/L, what is the solids loading rate in the clarifier in lbs/day/sq.ft.? (Round to the nearest tenth.)

**BOD and Suspended Solids Removed, lbs/day**

9. The flow to a secondary clarifier is 5.1 MGD. If the influent BOD concentration is 216 mg/L and the effluent BOD concentration is 103 mg/L, how many lbs/day BOD are removed daily?
  
  
  
  
  
  
  
  
  
  
10. The flow to a primary clarifier is 5,310,000 gpd. If the influent to the clarifier has a SS concentration of 190 mg/L and the primary effluent has 103 mg/L SS, how many lbs/day SS are removed by the clarifier?

**Unit Process Efficiency (or Removal), %**

11. The suspended solids entering a primary clarifier is 347 mg/L. If the suspended solids in the primary clarifier effluent is 125 mg/L, what is the suspended solids removal efficiency of the primary clarifier?
  
  
  
  
  
  
  
  
  
  
12. The influent to a primary clarifier has a BOD concentration of 99 mg/L. If the BOD content of the primary clarifier effluent is 13 mg/L, what is the BOD removal efficiency of the primary clarifier?

**Answers:**

1. 2.41 hrs
2. 1.49 hrs
3. 17,752.38 gpd/ft.
4. 14,331.21 gpd/ft.
5. 1,151.59 gpd/ft.
6. 969.07 gpd/ft.
7. 22.39 lb/day/sq.ft.
8. 21.55 lb/day/sq/ft.
9. 4,806.34 lb/day
10. 3,852.83 lb/day
11. 63.98%
12. 86.87%



5. A rectangular sedimentation basin is 60 ft long and 20 ft wide and contains water to a depth of 10 feet. If the flow to the basin is 1,520,000 gpd, what is the detention time in hours?
  
  
  
  
  
  
  
  
  
  
6. The influent flowrate to a primary sedimentation tank is 1.86 MGD. The tank is 83 feet in length, 20 feet wide, and has a water depth of 12.5 feet. What is the detention time of the tank in hours?
  
  
  
  
  
  
  
  
  
  
7. The flow to a rectangular sedimentation tank is 3.0 million gallons per day. Tank dimensions are 60 feet long by 30 feet wide by 10 feet deep. What is the detention time in hours? What is the detention time in minutes?

**Weir Overflow Rate, gpd/ft**

8. A rectangular clarifier has a total of 120 feet of weir. What is the weir overflow rate in gpd/ft when the flow is 1.5 MGD?
  
  
  
  
  
  
  
  
  
  
9. A circular clarifier receives a flow of 2.95 MGD. If the diameter of the weir is 70 ft, what is the weir overflow rate in gpd/ft?

10. A circular clarifier receives a flow of 2,520,000 gpd. If the diameter of the weir is 70 ft, what is the weir overflow rate in gpd/ft?
11. A rectangular sedimentation basin has a length of 50 ft and a width of 35 ft. If the flow to the basin is 1,890,000 gpd, what is the weir overflow rate in gpd/ft?
12. The flow is 5.0 MGD in a circular tank with a 90 foot weir diameter. What is the weir overflow rate in gallons per day per foot of weir length?
13. A primary sedimentation tank with a total weir length of 70 feet receives a flow rate of 1.38 MGD. What is the WOR in gpd/ft?
14. What is the weir overflow rate in gpd/ft, if the flow is 0.266 MGD and the radius of the clarifier is 39.9 ft?



20. A circular clarifier has a diameter of 70 ft. If the flow to the clarifier is 1610 gpm, what is the surface overflow in gpd/sq.ft.?
21. The flow into a rectangular clarifier is 4.0 MGD in a tank 92 feet long and 35 feet wide. What is the surface overflow rate in gpd/sq.ft. of surface area?

**Solids Loading Rate, lbs/day/sq.ft.**

22. A circular secondary clarifier with a diameter of 100 ft treats a flow of 3.5 MGD inflow and 1.0 MGD return sludge flow. If the MLSS concentration is 4200 mg/L, what is the solids loading rate in lbs/day/sq.ft.?
23. A secondary clarifier handles a flow of 0.9 MGD and a suspended solids concentration of 3600 mg/L. The clarifier is 50 ft in diameter. Find the solids loading rate in lbs/day/sq.ft.
24. A secondary clarifier is 70 ft in diameter and receives a combined primary effluent and return activated sludge (RAS) flow of 3.60 MGD. If the MLSS concentration in the aerator is 2650 mg/L, what is the solids loading rate on the secondary clarifier in lbs/day/sq.ft.?



25. A secondary clarifier, 80 ft in diameter, receives a primary effluent flow of 3.10 MGD and a return activated sludge flow of 1.15 MGD. If the MLSS concentration is 2825 mg/L, what is the solids loading rate on the clarifier in lbs/day/sq.ft.?
26. A secondary clarifier, 60 ft in diameter, receives a primary effluent flow of 2,550,000 gpd and a return activated sludge flow of 800,000 gpd. If the MLSS concentration is 2210 mg/L, what is the solids loading rate on the clarifier in lbs/day/sq.ft.?
27. What is the solids loading rate for a secondary clarifier, given the following information?
- Radius of clarifier = 65.4 ft
  - Primary effluent flow = 3,779,000 gpd
  - Return sludge flow = 725,000 gpd
  - Mixed liquor suspended solids = 2,110 mg/L
28. A circular secondary clarifier with a diameter of 100 feet treats a flow of 4.5 MGD (3.5 MGD inflow and 1.0 MGD return sludge flow) with a mixed liquor suspended solids concentration of 4,200 mg/L. What is the solids loading rate in pounds of solids per day per square foot of surface area?

**BOD and Suspended Solids Removed, lbs/day**

29. If 110 mg/L suspended solids are removed by a primary clarifier, how many lbs/day suspended solids are removed when the flow is 6,150,000 gpd?
30. If 125 mg/L suspended solids are removed by a primary clarifier, how many lbs/day suspended solids are removed when the flow is 5.16 MGD?
31. The flow to a primary clarifier is 2,920,000 gpd. If the influent to the clarifier has a BOD concentration of 240 mg/L and the primary effluent has a 200 mg/L BOD, how many lbs/day BOD are removed by the clarifier?
32. The flow to a secondary clarifier is 4.44 MGD. If the influent BOD concentration is 200 mg/L and the effluent concentration is 110 mg/L, how many lbs of BOD are removed daily?
33. The flow to a primary clarifier is 980,000 gpd. If the influent to the clarifier has a suspended solids concentration of 320 mg/L and the primary clarifier effluent has a suspended solids concentration of 120 mg/L, how many lbs/day suspended solids are removed by the clarifier?

34. Given the following data, determine the amount of solids produced in lb/day.
- Flow = 1,248,000 gpd
  - Influent suspended solids = 295 mg/L
  - Primary effluent suspended solids = 106 mg/L
35. If 120 mg/L suspended solids are removed by a primary clarifier, how many lbs/day suspended solids are removed when the flow is 6,250,000 gpd?

**Unit Process Efficiency (or Removal), %**

36. The suspended solids entering a primary clarifier is 182 mg/L. If the suspended solids concentration in the primary clarifier effluent is 79 mg/L, what is the suspended solids removal efficiency of the primary clarifier?
37. The influent to a primary clarifier has a BOD content of 260 mg/L. If the primary clarifier effluent has a BOD concentration of 54 mg/L, what is the BOD removal efficiency?

38. The suspended solids entering a primary clarifier is 230 mg/L. If the suspended solids concentration in the primary clarifier effluent is 95 mg/L, what is the suspended solids removal efficiency of the primary clarifier?
39. The concentration of suspended solids entering a primary clarifier is 188 mg/L. If the concentration of suspended solids in the primary clarifier effluent is 77 mg/L, what is the suspended solids removal efficiency of the primary clarifier?
40. The influent to a primary clarifier has a BOD content of 280 mg/L. If the primary clarifier effluent has a BOD concentration of 60 mg/L, what is the BOD removal efficiency of the primary clarifier?
41. The influent BOD to a primary clarifier is 200 mg/L, and effluent BOD is 140 mg/L. What is the efficiency of the primary clarifier in removing BOD?

**Challenge Problems**

42. A circular clarifier has a diameter of 80 feet and an average depth of 10 feet. The flow of wastewater is 4.0 MGD and the suspended solids concentration is 190 mg/L. Calculate the following:
- Detention Time, in hours
  - Weir Overflow Rate, in gpd/ft
  - Surface Overflow Rate, in gpd/sq. ft.

43. A wastewater treatment plant has eight primary tanks. Each tank is 82 feet long, 21 feet wide, with a side water depth of 13 feet and a total weir length of 88 feet. The flowrate to the plant is 5.1 MGD. There are three tanks currently in service.

Calculate the following:

- a) Detention time, in minutes
- b) Weir Overflow Rate, in gpd/ft
- c) Surface Overflow Rate in gpd/ft<sup>2</sup>

If the plant flowrate has increased to 9.8 MGD due to storm flow, how many of the eight primary sedimentation tanks should be in service to operate within these conditions:

- 1) Detention time between 90 and 150 minutes
- 2) WOR below 20,000 gpd/ft
- 3) SOR between 800 and 1000 gpd/ft<sup>2</sup>

**Answers:**

1. 1.309 hrs
2. 1.94 hrs
3. 1.42 hrs
4. 3.71 hrs
5. 1.42 hrs
6. 2.00 hrs
7. 1.08 hrs  
or 64.8 mins
8. 12,500 gpd/ft.
9. 13,421.29 gpd/ft.
10. 11,464.97 gpd/ft.
11. 11,117.65 gpd/ft.
12. 17,692.85 gpd/ft.
13. 19,714.29 gpd/ft.
14. 1061.57 gpd/ft.
15. 873.82 gpd/sq.ft.
16. 927.11 gpd/sq.ft.
17. 1142.86 gpd/sq.ft.
18. 965.87 gpd/sq.ft.
19. 489.6 gpd/sq.ft.
20. 602.73 gpd/sq.ft.
21. 1242.24 gpd/sq.ft.
22. 20.08 lb/day/sq.ft.
23. 13.77 lb/day/sq.ft.
24. 20.68 lb/day/sq.ft.
25. 19.93 lb/day/sq.ft.
26. 21.85 lb/day/sq.ft.
27. 5.90 lb/day/sq.ft.
28. 20.01 lb/day/sq.ft.
29. 5640.01 lb/day
30. 5379.3 lb/day
31. 974.11 lb/day
32. 3332.66 lb/day
33. 1634.64 lb/day
34. 1967.17 lb/day
35. 6255 lb/day
36. 56.59%
37. 79.23%
38. 58.7%
39. 59.04%
40. 78.57%
41. 30%
42. (a) 2.25 hrs  
(b) 15,923.57  
gpd/ft.  
(c) 796.18 gpd/sq.ft.
43. (a) 141.84 min  
(b) 19,318 gpd/ft.  
(c) 987.22 gpd/sq.ft.

continued...

- (1) 4 tanks
- (2) 6 tanks
- (3) 6 or 7 tanks





**Section 8**

**Trickling Filters**

**and RBCs**

Applied Math for Wastewater Systems

## TRICKLING FILTER AND RBC CALCULATIONS

### Trickling Filters

- ⦿ An aerobic treatment system that utilizes microorganisms attached to a medium to remove organic matter from wastewater.
- ⦿ These systems are known as *attached-growth* processes.
  - In contrast, systems in which microorganisms are sustained in a liquid are known as *suspended-growth* processes.
- ⦿ This type of system is common to a number of technologies such as rotating biological contactors and packed bed reactors (biotowers).

## Trickling Filters

- TFs enable organic material in the wastewater to be adsorbed by a population of microorganisms (aerobic, anaerobic, and facultative bacteria; fungi; algae; and protozoa) attached to the medium as a biological film or slime layer
- As the wastewater flows over the medium, microorganisms already in the water gradually attach themselves to the rock, slag, or plastic surface and form a film.
- The organic material is then degraded by the aerobic microorganisms in the outer part of the slime layer.

## Trickling Filters

- The growth is a shiny slime similar to the slime found on rocks in a stream
  - Biomass
  - Zoogleal mass
  - Biofilm
  - Slime growth

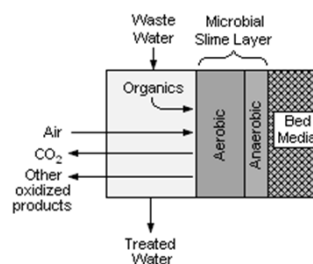

# Trickling Filters



# Trickling Filters

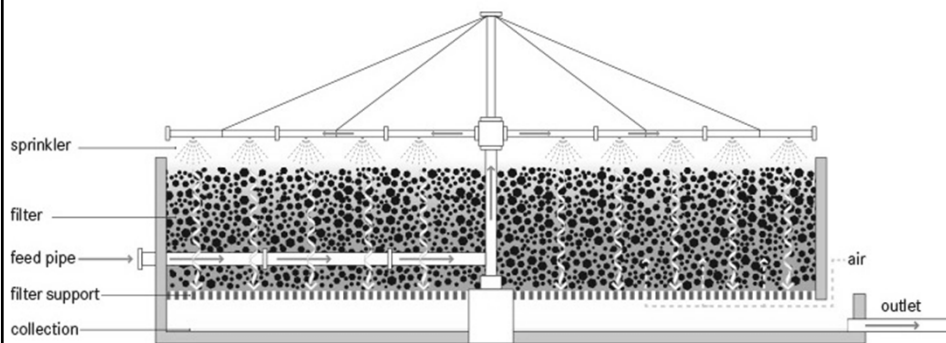

## Trickling Filter Calculations

- ⦿ Hydraulic Loading Rate
- ⦿ Organic Loading Rate
- ⦿ BOD Removed
- ⦿ Suspended Solids Removed
- ⦿ Unit Process or Overall % Efficiency
- ⦿ Recirculation Ratio

## Hydraulic Loading Rate

- ⦿ Associated with the contact time between the microorganisms in the zoogeal mass and the food in the influent
- ⦿ The total flow loaded or entering each square foot of water surface area
  - You must account for both primary effluent and recirculated effluent (they are combined before being applied to filter surface)
  - Recirculated flows must be included!

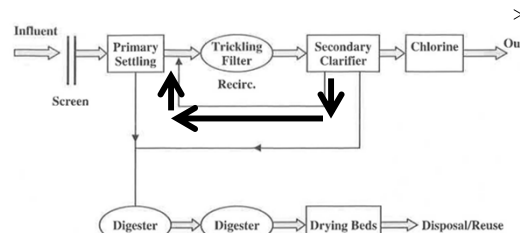

## Hydraulic Loading Rate

- Hydraulic Loading Rate =

$$\frac{\text{Total Flow Applied, gpd}}{\text{Surface area, sq ft}}$$

$$\frac{\text{Total Flow Applied, MGD}}{\text{Area, acre}}$$

$$\frac{\text{Primary Effluent Flow Rate, gpd} + \text{Recirculated Flow Rate, gpd}}{\text{Surface area, sq ft}}$$

## Hydraulic Loading Rate

- Example 1:* A trickling filter 80 ft in diameter treats a primary flow of 450,000 gpd. If the recirculated flow to the clarifier is 0.1 MGD, what is the HLR on the TF?

- HLR =  $\frac{\text{Total Flow, gpd}}{\text{Surface area, sq ft}}$

- HLR =  $\frac{550,000 \text{ gpd}}{(0.785)(80 \text{ ft})(80 \text{ ft})}$  ← 0.45 MGD + 0.1 MGD = 0.55 MGD

- HLR = 109 gpd/sq ft. ← Area formula for circle

## Hydraulic Loading Rate

- ⊙ Example 2: A high rate TF receives a flow of 2200 gpm. If the filter has a diameter of 95 ft, what is the HLR on the filter?
- ⊙ First, convert 2200 gpm into gpd.
  - $\frac{2200 \text{ gal}}{1 \text{ min}} \times \frac{1440 \text{ min}}{1 \text{ day}} = 3,168,000 \text{ gpd}$
- ⊙  $\text{HLR} = \frac{\text{Total Flow, gpd}}{\text{Surface area, sq ft}}$
- ⊙  $\text{HLR} = \frac{3,168,000 \text{ gpd}}{(0.785)(95 \text{ ft})(95 \text{ ft})}$  ← Area formula for circle
- ⊙  $\text{HLR} = 447 \text{ gpd/sq ft}$

## Organic Loading Rate

- ⊙ Calculating the food entering the filter
- ⊙ Often calculated as lbs BOD/day per 1000 cu ft
  - Sometimes calculated as lbs/day BOD/per cu ft
  - Or lbs BOD/day per acre-foot
- ⊙ Often BOD will be in mg/L concentration and you must convert to lbs/day BOD
- ⊙ Note: the “1000” in the denominator is a unit of measure (“thousand cu ft”) and **is not part of the numerical calculation.**

## Organic Loading Rate

$$\odot \text{OLR} = \frac{\text{Organic load, lbs BOD}_5/\text{day}}{\text{Volume, 1000 cu ft}}$$

Expanded Formula:

$$\odot \text{OLR} = \frac{\text{Pounds Formula!}}{\text{Volume of a cylinder formula}}$$

$$\odot \text{OLR} = \frac{(\text{Conc of BOD, mg/L})(\text{Flow, MGD})(8.34 \text{ lbs/gal})}{\frac{(0.785)(D^2)(\text{depth, ft})}{1000}}$$

Volume of a cylinder formula

## Organic Loading Rate

- Example 1:* A TF 80 ft in diameter with a media depth of 8 ft receives a flow of 950,000 gpd. If the BOD concentration of the primary effluent is 210 mg/L, what is the organic loading on the TF in lbs/day/1000 cu ft?



## Example 1 continued

$$\odot \text{ OLR} = \frac{(\text{Conc of BOD,mg/L})(\text{Flow,MGD})(8.34)}{\frac{(0.785)(D^2)(\text{depth, ft})}{1000}}$$

$$\odot \text{ OLR} = \frac{(210\text{mg/L}) ( 0.95 \text{ MGD})(8.34)}{\frac{(0.785)(80 \text{ ft})(80 \text{ ft})(8 \text{ ft})}{1000}}$$

$$\odot \text{ OLR} = \frac{1663.83 \text{ lbs BOD/day}}{40.192 \text{ } 1000 \text{ cu ft}}$$

$$\odot \text{ OLR} = \frac{41 \text{ lbs BOD/day}}{1000 \text{ cu ft}}$$

## BOD and SS Removed

- ⊙ Calculation of the BOD or suspended solids removed
- ⊙ You need the BOD or SS removed and the plant flow
  - *Use the Pounds formula!*

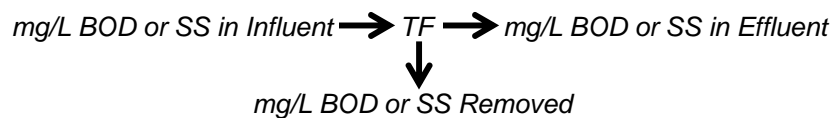

## BOD or SS Removed

- ⦿ *Example 1:* If 110 mg/L suspended solids are removed by a TF, how many lbs/day suspended solids are removed when the flow is 4.2 MGD?
- ⦿ *Pounds formula!*
- ⦿ SS Removed = (Concentration, mg/L) (Flow, MGD) (8.34)
- ⦿ SS Removed = (110 mg/L) (4.2 MGD) (8.34)
- ⦿ SS Removed = 3853 lbs SS/day

## Unit Process or Overall Efficiency

- ⦿ The efficiency of a treatment process is its effectiveness in removing various constituents from the wastewater.
- ⦿ Unit process and overall efficiency use the same equation

$$\% \text{ Removed} = \frac{\text{BOD or SS Removed, mg/L}}{\text{BOD or SS Total, mg/L}} \times 100$$

$$\text{same as.... Removal, \%} = \left( \frac{\text{In} - \text{Out}}{\text{In}} \right) \times 100$$

- ⦿ When calculating **unit process efficiency**, you need the BOD or SS concentration of the **TF influent** and the **TF effluent**
- ⦿ When calculating **overall efficiency**, you need the BOD or SS concentration of the **plant influent** and the **plant effluent**

## Unit Process Efficiency

- ◎ *Example 1:* The suspended solids entering a TF is 135 mg/L. If the suspended solids in the TF effluent is 28 mg/L, what is the suspended solids removal efficiency of the TF?
- ◎ % SS Removed =  $\frac{\text{SS Removed,mg/L}}{\text{SS Total,mg/L}} \times 100$
- ◎ % SS Removed =  $\frac{107 \text{ mg/L}}{135 \text{ mg/L}} \times 100$
- ◎ % SS Removed = 79%

## Recirculation Ratio

- ◎ The ratio of the recirculated TF flow to the primary effluent flow
- ◎ The ratio is often found to be 1:1 or 2:1
- ◎ Recirculation of trickling filter or final clarifier effluent may be used for various reasons such as:
  - Reducing TF detention time
  - Increasing hydraulic loading rate
  - Decreasing the TF influent strength
  - All of which improve the ability to handle shock loads
    - It's also used to keep the filter wet during periods of low flow

## Recirculation Ratio

● Recirculation Ratio =  $\frac{\text{Recirculated Flow, MGD}}{\text{Primary Effluent Flow, MGD}}$

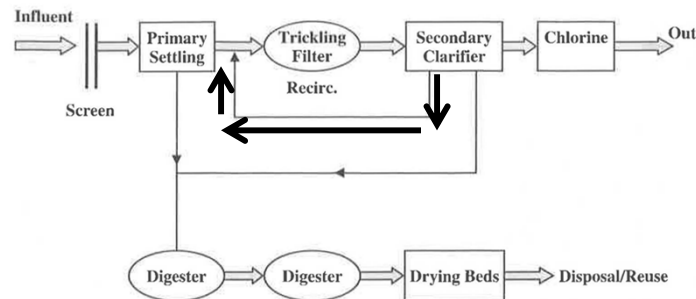

## Recirculation Ratio

- *Example:* A treatment plant receives a flow of 2.5 MGD. If the TF effluent is recirculated at the rate of 4.25 MGD, what is the recirculation ratio?

● Recirculation Ratio =  $\frac{\text{Recirculated Flow, MGD}}{\text{Primary Effluent Flow, MGD}}$

● Recirculation Ratio =  $\frac{4.25 \text{ MGD}}{2.5 \text{ MGD}}$

● Recirculation Ratio = 1.7

## Rotating Biological Contactors

- RBC
- Fixed film, a variation on the TF
- Closely spaced disks with 40% submerged in wastewater stream
- As RBC rotates, the attached growth (biomass) on the surface of the disks move in and out of the water
- When submerged, the microorganisms adsorb organics
- When out of the water, they are supplied with oxygen needed for aerobic decomposition

## Rotating Biological Contactor

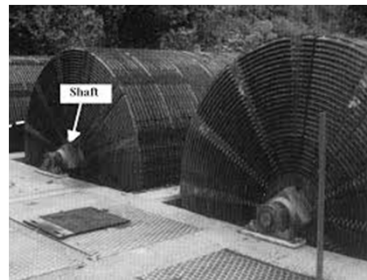
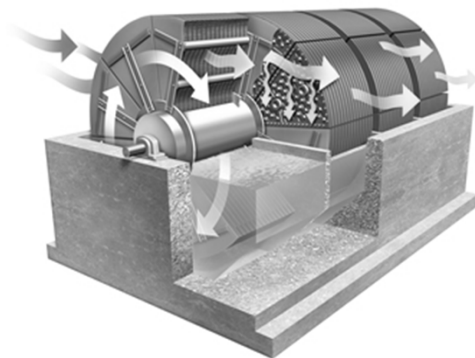

## Rotating Biological Contactor

- ⦿ Organic Loading Rate
  - Can be expressed as total BOD loading in pounds per day per 1000 sq ft of media
  - Soluble BOD measures organic content rather than total BOD

$$\text{⦿ OLR} = \frac{\text{Soluble BOD, lbs/day}}{\text{Media Area, 1000 sq ft}}$$

Expanded Formula:

$$\text{⦿ OLR} = \frac{(\text{Soluble BOD, mg/L})(\text{Flow, MGD})(8.34 \text{ lbs/gal})}{\text{Media Area, 1000 sq ft}}$$

## Rotating Biological Contactor

- ⦿ To find how many 1000 sq ft, move the decimal place 3 places to the left
  - Ex: 500,000 sq ft is 500 units of 1000 sq ft
- ⦿ In most instances, BOD will be expressed as a mg/L concentration and must be converted to lbs/day BOD
- ⦿ The “1000” in the denominator is a unit of measure (“thousand sq ft”) and is not part of the numerical calculation

## RBC – Organic Loading Rate

- *Example:* An RBC has a media surface area of 500,000 sq ft and receives a flow of 1,200,000 gpd. If the soluble BOD concentration of the primary effluent is 170 mg/L, what is the organic loading on the RBC in lbs/day/1000 sq ft?
- $OLR = \frac{\text{Soluble BOD, lbs/day}}{\text{Media Area, 1000 sq ft}}$
- $OLR = \frac{(170\text{mg/L})(1.2\text{ MGD})(8.34\text{lb/gal})}{500 \ 1000 \text{ sq ft}}$
- $OLR = 3.4 \text{ lbs/day soluble BOD/1000 sq ft}$

Any Questions?

**Applied Math for Wastewater Treatment  
Trickling Filter and Rotating Biological Contactors Math**

**Trickling Filters (TF)**

**Hydraulic Loading Rate, gpd/sq.ft.**

1. A standard rate filter, 90 feet in diameter, treats a primary effluent flow of 540,000 gpd. If the recirculated flow to the trickling filter is 120,000 gpd, what is the hydraulic loading rate on the filter in gpd/sq.ft.?
  
  
  
  
  
  
  
  
  
  
2. A trickling filter, 75 feet in diameter, treats a primary effluent flow of 640,000 gpd. If the recirculated flow to the trickling filter is 110,000 gpd, what is the hydraulic loading rate in gpd/sq.ft. on the trickling filter?

**Organic Loading Rate, lbs/day/1000 cu. ft.**

3. A trickling filter, 85 feet in diameter with a media depth of 5 feet, receives a flow of 1,200,000 gpd. If the BOD concentration of the primary effluent is 160 mg/L, what is the organic loading on the trickling filter in lbs BOD/day/1000 cu.ft.?



4. A trickling filter, 80 feet in diameter with a media depth of 6 feet, receives a flow of 3,240,000 gpd. If the BOD concentration of the primary effluent is 110 mg/L, what is the organic loading on the trickling filter in lbs BOD/day/1000 cu.ft.?

### **BOD and Suspended Solids Removed**

5. If a trickling filter removes 177 mg/L BOD when the flow is 2,840,000 gpd, how many lbs/day BOD are removed?
  
  
  
  
  
  
  
  
  
  
6. The suspended solids concentration entering a trickling filter is 210 mg/L. If the suspended solids concentration in the trickling filter effluent is 67 mg/L, what is the suspended solids removal efficiency of the trickling filter?

### **Unit Process Efficiency (or Removal), %**

7. The influent to a primary clarifier has a BOD content of 252 mg/L. The trickling filter effluent BOD is 20 mg/L. What is the BOD removal efficiency of the treatment plant?

**Recirculation Ratio**

8. A treatment plant receives a flow of 2.5 MGD. If the trickling filter effluent is recirculated at the rate of 4.25 MGD, what is the recirculation ratio?

**Rotating Biological Contactors (RBC)****Hydraulic Loading Rate, gpd/sq.ft.**

9. A RBC treats a primary effluent flow of 1.85 MGD. If the media surface area is 600,000 sq. ft., what is the HLR on the RBC?

**Organic Loading Rate, lb SBOD/day/1,000 sq.ft.**

10. The wastewater flow to an RBC is 3,110,000 gpd. The wastewater has a soluble BOD concentration of 122 mg/L. The RBC consists of 6 shafts (each 100,000 sq. ft.), with 2 shafts comprising the first stage of the system. What is the organic loading rate lbs/day/1,000 sq.ft. on the first stage of the system.

**Answers:**

1. 103.80 gpd/sq.ft.
2. 169.85 gpd/sq.ft.
3. 56.47 lbs/day/1000 cu.ft.
4. 98.61 lbs/day/1000 cu.ft.
5. 4192.35 lbs/day
6. 68 %
7. 92 %
8. 1.7
9. 3.08 gpd/sq. ft.
10. 15.82 lb/day/1000 sq ft



5. A trickling filter receives a flow of 2200 gpm with a BOD concentration of 125 mg/L. If the filter is 95 feet in diameter, what is the hydraulic loading rate, gpd/sq.ft.?
  
  
  
  
  
  
  
  
  
  
6. A high rate trickling filter is fed by a pump rated at 2,100 gpm and the filter diameter is 100 feet. What is the HLR in gpd/sq.ft.?
  
  
  
  
  
  
  
  
  
  
7. A trickling filter 80 feet in diameter treats a primary effluent flowrate of 0.296 MGD. If the recirculated flow to the clarifier is 0.348 MGD, what is the hydraulic loading rate on the trickling filter in gallons per day per square foot?

**Organic Loading Rate, lbs BOD/day/1,000 cu.ft.**

8. A trickling filter 80 ft in diameter with a media depth of 4 ft receives a primary effluent flow of 1.85 MGD with a BOD concentration of 110 mg/L. What is the organic loading rate, lbs BOD/day/1000 cu ft?

9. An 80 ft diameter trickling filter with a media depth of 7 ft receives a flow of 2,180,000 gpd. If the BOD concentration of the primary effluent is 139 mg/L, find the organic loading rate.
10. A trickling filter, 100 ft in diameter with a media depth of 6 ft, receives a flow of 1,400,000 gpd. If the BOD concentration of the primary effluent is 210 mg/L, what is the organic loading on the trickling filter in lbs BOD/day/1000 ft<sup>3</sup>?
11. A 90-ft diameter trickling filter with a media depth of 7 ft receives a primary effluent flow of 3,400,000 gpd with a BOD of 111 mg/L. What is the organic loading on the trickling filter in lbs BOD/day/1000 ft<sup>3</sup>?
12. Calculate OLR for the following trickling filter:
- |                   |                        |
|-------------------|------------------------|
| Diameter: 75 ft   | Flow: 315 gpm          |
| Media depth: 5 ft | Influent BOD: 210 mg/L |

13. A trickling filter 70 feet in diameter with a media depth of 5 feet receives a primary effluent flowrate of 1,150,000 gpd. If the PE BOD is 74 mg/L, what is the organic loading rate on the unit in pounds per day per 1000 cubic feet? What is the loading rate in pounds per day per ac-ft?
14. What is the organic loading rate in lb BOD/day/1,000 ft<sup>3</sup> for a trickling filter that is 68.5 ft in diameter and 5.05 ft deep, if the primary effluent flow is 2.46 mgd and the BOD is 149 mg/L?

### **BOD & Suspended Solids Removal**

15. If 110 mg/L suspended solids are removed by a trickling filter, how many pounds per day suspended solids are removed when the flow is 4.2 MGD?
16. If a trickling filter removes 113 mg/L suspended solids, how many lbs/day suspended solids are removed when the flow is 2,668,000 gpd?

17. A trickling filter receives a flow of 4,900,000 gpd. If the BOD concentration entering the trickling filter is 160 mg/l and the effluent contains 30 mg/L, how many pounds of BOD are removed daily?
18. If 122 mg/L suspended solids are removed by a trickling filter, how many lbs/day suspended solids are removed when the flow is 3,240,000 gpd?
19. The flow to a trickling filter is 1.82 MGD. If the primary effluent has a BOD concentration of 250 mg/L and the trickling filter effluent has a BOD concentration of 74 mg/L, how many lbs of BOD are removed?



20. The flowrate to a trickling filter is 3.7 MGD. If the primary effluent BOD is 79 mg/L and the secondary effluent BOD is 14 mg/L, how many pounds of BOD are removed daily?
21. The 3,700,000 gpd influent flow to a trickling filter has a BOD content of 185 mg/L. If the trickling filter effluent has a BOD content of 68 mg/L, how many pounds of BOD are removed daily? How many pounds are removed per hour?

**Unit Process Efficiency (or Removal), %**

22. The suspended solids concentration entering a trickling filter is 135 mg/L. If the suspended solids in the effluent is 28 mg/L, what is the suspended solids removal efficiency, %? If the flow to the filter is 1.5 cfs, calculate lbs/day suspended solids removed.
23. The suspended solids concentration entering a trickling filter is 149 mg/L. If the suspended solids concentration in the trickling filter effluent is 48 mg/L, what is the suspended solids removal efficiency of the trickling filter?

24. The influent to a primary clarifier has a BOD content of 261 mg/L. The trickling filter effluent BOD is 22 mg/L. What is the BOD removal efficiency of the treatment plant?
25. The concentration of suspended solids entering a trickling filter is 201 mg/L. If the concentration of suspended solids in the trickling filter effluent is 22 mg/L, what is the suspended solids removal efficiency of the trickling filter?
26. The concentration of suspended solids entering a trickling filter is 111 mg/L. If 88 mg/L suspended solids are removed from the trickling filter, what is the suspended solids removal efficiency of the trickling filter?
27. Calculate the efficiency of a trickling filter plant if the suspended solids of the plant influent are 200 mg/L and the plant effluent suspended solids are 20 mg/L.

28. Calculate the efficiency of just the trickling filter if the suspended solids in the primary clarifier effluent (the trickling filter influent) are 140 mg/L and the plant effluent suspended solids are 20 mg/L.

### **Recirculation Ratio**

29. The influent to a trickling filter is 5 MGD. If the recirculated flow is 7.4 MGD, what is the recirculation ratio?
30. A treatment plant receives a flowrate of 2.5 MGD. If the trickling filter effluent is recirculated at a rate of 4.25 MGD, what is the recirculation ratio?
31. A treatment plant receives a flow of 3.4 MGD. If the trickling filter effluent is recirculated at the rate of 3.5 MGD, what is the recirculation ratio?
32. The influent to the trickling filter is 1.64 MGD. If the recirculated flow is 2.32 MGD, what is the recirculation ratio?

33. The trickling filter effluent is recirculated at the rate of 2.96 MGD. If the treatment plant receives a flow of 2.17 MGD, what is the recirculation ratio?
34. A trickling filter has a desired recirculation ratio of 1.6. If the primary effluent flow is 4.6 MGD, what is the desired recirculated flow in MGD?
35. Given the following information about a trickling filter, determine the primary effluent flow.  
Recirculation Ratio: 1.9                      Recirculated Flow: 3.77 MGD

**Rotating Biological Contactors (RBCs)**  
**Hydraulic Loading Rate, pgd/sq.ft.**

36. A rotating biological contactor treats a flow of 2.6 MGD. The manufacturer's data indicates a media surface area of 500,000 sq. ft. What is the hydraulic loading rate on the RBC?
37. An RBC unit treats a flowrate of 0.35 MGD. The two shafts used provide a total surface area of 195,000 ft<sup>2</sup>? What is the HLR on the unit in gpd/ft<sup>2</sup>?

38. Assume a media surface area of 440,000 square feet and that the rotating biological contactor treats a flow of 1.55 MGD. What is the hydraulic loading rate on the RBC in gpd/sq ft?
39. A RBC has a media area of 800,000 sq ft. For a maximum HLR of 7 gpd/sq ft, what is the desired gallons per day flow to the contactor?

**Organic Loading Rate, lb SBOD/day/1,000 sq ft.**

40. The wastewater flow to an RBC is 2,820,000 gpd. The wastewater has a soluble BOD concentration of 128 mg/L. The RBC media has a total surface area of 660,000 square feet. What is the organic loading rate on the RBC in lb/day/1000 sq ft?
41. A wastewater flow to an RBC is 5,750,000 gpd. The wastewater has a soluble BOD concentration of 150 mg/L. The RBC consists of 6 shafts, each 100,000 sq ft, with 2 shafts comprising the first stage of the system. What is the organic loading rate lbs/day/1000 sq ft on the first stage of the system?

42. An RBC receives a flowrate of 1.4 MGD. If the influent soluble BOD concentration is 122 mg/L and the total media surface area is 392,000 ft<sup>2</sup> for the RBC unit, what is the organic loading in lbs/day/1000 ft<sup>2</sup>?
43. Calculate the OLR for an RBC given the following information:  
Influent flow: 2.4 MGD  
Soluble BOD concentration: 105 mg/L  
Surface area of media: 700,000 ft<sup>2</sup>
44. An RBC has a media surface area of 640,000 sq ft and receives a flow of 1,520,000 gpd. If the soluble BOD concentration of the primary effluent is 179 mg/L, what is the organic loading rate on the RBC in lb/day/1000 sq ft?
45. The organic loading rate for an RBC has been calculated to be 5 lbs Soluble BOD/day/1000 sq ft. If the influent flow is 2,975,000 gpd and has an SBOD concentration of 188 mg/L, what is the surface area of the media (in sq ft)?

## Answers:

1. 384.99 gpd/sq ft
2. 89.57 gpd/sq ft
3. 155.25 gpd/sq ft
4. 534.47 gpd/sq ft
5. 447.17 gpd/sq ft
6. 385.22 gpd/sq ft
7. 128.18 gpd/sq ft
8. 84.45 lb BOD/day/1000 cu ft
9. 71.86 lb BOD/day/1000 cu ft
10. 52.01 lb BOD/day/1000 cu ft
11. 70.72 lb BOD/day/1000 cu ft
12. 35.98 lb BOD/day/1000 cu ft
13. 36.90 lb BOD/day/1000 cu ft  
or 1607 lb BOD/ac-ft
14. 164.34 lb BOD/day/1000 cu ft
15. 3853.08 lb/day
16. 2514.38 lb/day
17. 5312.58 lb/day
18. 3296.64 lb/day
19. 2671.47 lb/day
20. 2005.77 lb/day
21. 3610.39 lb/day
22. 79%
23. 68%
24. 92%
25. 89%
26. 79%
27. 90%
28. 85.71%
29. 1.48
30. 1.7
31. 1.03
32. 1.41
33. 1.36
34. 7.36 MGD
35. 1.98 MGD
36. 5.2 gpd/sq ft
37. 1.79 gpd/sq ft
38. 3.52 gpd/sq ft
39. 5,600,000 gpd
40. 4.56 lb SBOD/day/1000 sq ft.
41. 35.82 lb SBOD/day/1000 sq ft
42. 3.63 lb SBOD/day/1000 sq ft
43. 3.00 lb SBOD/day/1000 sq ft
44. 3.55 lb SBOD/day/1000 sq ft
45. 932.91 1000 sq ft





## **Section 9**

### **Pumps**

# Pumps, Power and Force



## Horsepower and Efficiency

...

• TDEC - Fleming Training Center

## Understanding Work & Horsepower

- Work: The exertion of force over a specific distance.
  - Example: Lifting a one-pound object one foot.
- Amount of work done would be measured in foot-pounds
  - (feet) (pounds) = foot-pounds
- (1 pound object) ( moved 20 ft) = 20 ft-lbs of work

• TDEC - Fleming Training Center

• 3

## Understanding Power

- Power is the measure of how much work is done in a given amount of time
- The basic units for power measurement is foot-pounds per minute and expressed as (ft-lb/min)
  - in electric terminology  $\Rightarrow$  Watts
- This is work performed per time (work/time)
- One Horsepower
  - 1 HP = 33,000 ft-lb/min
- In electric terms
  - 1 HP = 746 Watts

• TDEC - Fleming Training Center

• 4

## Types of Horsepower

- **Motor Horsepower** is related to the watts of electric power supplied to a motor
- **Brake Horsepower** is the power supplied to a pump by a motor
- **Water Horsepower** is the portion of power delivered to a pump that is actually used to lift the water
  - Water horsepower is affected by elevation and location of the pump.

• TDEC - Fleming Training Center

• 5

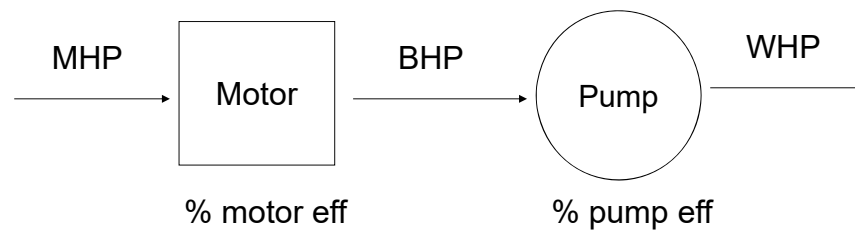

Left to right → multiply

Right to left → divide

# Computing Water Horsepower

- Water horsepower is the amount of horsepower required to lift the water

$$WHP = \frac{(\text{flow gpm})(\text{total head feet})}{3,960}$$

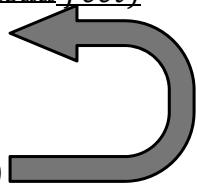
$$\frac{33,000 \text{ ft} - \text{lb} / \text{min}}{8.34 \text{ lbs} / \text{gal}} = 3960$$

## Example 1

- A pump must pump 3,000 gpm against a total head of 25 feet. What water horsepower will be required?

$$\begin{aligned} \text{WHP} &= \frac{(3000 \text{ gpm})(25 \text{ head in ft})}{3960} \\ &= 18.94 \end{aligned}$$

## Brake Horsepower

$$bhp = \frac{(flow, gpm)(head, ft)}{(3960)(\% pump\ eff.)}$$

OR

$$bhp = \frac{water\ hp}{\% pump\ eff.}$$

• TDEC - Fleming Training Center

• 9

## Example 2

- Determine the horsepower produce by a motor at a flow of 1500 gpm against a total head of 25 ft if the pump is 82% efficient.

$$bhp = \frac{(flow, gpm)(head, ft)}{(3960)(\% pump\ eff.)}$$

$$bhp = \frac{(1500\ gpm)(25\ ft)}{(3960)(0.82)}$$

$$bhp = \frac{37500}{3247.2}$$

$$bhp = 11.5\ hp$$

•

•

## Motor Horsepower

$$mhp = \frac{(flow, gpm)(head, ft)}{(3960)(\% pump\ eff)(\% motor\ eff)}$$

$$mhp = \frac{water\ hp}{(\% pump\ eff)(\% motor)}$$

$$mhp = \frac{bhp}{\% motor\ eff}$$

• TDEC - Fleming Training Center

• 11

## Example 3

- A certain pumping job will require 9 hp. If the pump is 80% efficient and the motor is 72% efficient, what motor horsepower will be required?

$$mhp = \frac{water\ hp}{(\% pump\ eff)(\% motor)}$$

$$mhp = \frac{9\ hp}{(0.80)(0.72)}$$

$$mhp = \frac{9\ hp}{0.576}$$

$$mhp = 15.6\ hp$$

## Motor and Pump Efficiency

- Neither the motor nor the pump will ever be 100% efficient
- Not all the power supplied by the motor to the pump (Brake Horsepower) will be used to lift the water (Water Horsepower)
- Power for the motor and pump is used to overcome friction
- Power is also lost when energy is converted to heat, sound, etc.

## Typical Efficiency

- Pumps are generally 50-85 % efficient
- Motors are usually 80-95% efficient
- Combined efficiency of the motor and pump is called wire-to-water efficiency



## Wire-to-Water Efficiency

$$w - w = \frac{\text{water hp}}{\text{motor hp}} \times 100$$

OR

$$w - w = \frac{(\text{flow, gpm})(\text{head, ft})(0.746 \text{ kW/hp})}{(3960)(\text{electric demand, kW})} \times 100$$

## Example 4

- A pump must move 2500 gpm against a total dynamic head of 115 feet. If the motor requires 75 kW of power, what is the wire-to-water efficiency?

$$w - w = \frac{(\text{flow, gpm})(\text{head, ft})(0.746 \text{ kW/hp})}{(3960)(\text{electric demand, kW})} \times 100$$

$$w - w = \frac{(2500 \text{ gpm})(115 \text{ ft})(0.746 \text{ kW/hp})}{(3960)(75 \text{ kW})} \times 100$$

$$w - w = \frac{214475}{297000} \times 100$$

$$w - w = 72.2\%$$

# Electrical

• • •

## A Few Electrical Terms...

- Power (Watts) - amount of work done
- Voltage (volts) - electrical "pressure" available to cause flow of electricity
- Amperage (amps) - the amount of flow of electricity
- Power = (voltage)(amperage)  
or
- Watts = (volts)(amps)

# Amperage

- Current is equal to the voltage applied to the circuit divided by the resistance of the circuit
- Ohm's Law:

$$\text{amps} = \frac{\text{volts}}{\text{ohms}}$$

# Example 5

- A circuit contains a resistance of 6 ohms and a source voltage of 3 volts. How much current (amps) flows in the circuit?

$$\text{amps} = \frac{\text{volts}}{\text{ohms}}$$

$$\text{amps} = \frac{3 \text{ volts}}{6 \text{ ohms}}$$

$$\text{amps} = 0.5 \text{ amps}$$

## Electromotive Force

- Electromotive force is the characteristic of any energy source capable of driving electric charge around a circuit
  - Aka voltage

$$emf, \text{ volts} = (\text{current, amps})(\text{resistance, ohms})$$

## Example 6

- A circuit has a resistance of 12 ohms with a current of 0.25 amps. What is the electromotive force in volts?

$$emf, \text{ volts} = (\text{current, amps})(\text{resistance, ohms})$$

$$emf = (0.25 \text{ amps})(12 \text{ ohms})$$

$$emf = 3 \text{ volts}$$

## Watts

- Unit of power
- $1 \text{ hp} = 0.746 \text{ Kw}$
- $1 \text{ hp} = 746 \text{ W}$
- Alternating current (AC circuit)

$$\text{Watts} = (\text{volts})(\text{amps})(\text{power factor})$$

$$W = V * A * pf$$

- Direct current (DC circuit)

$$\text{Watts} = (\text{volts})(\text{amps})$$

$$W = V * A$$

## Example 7

- An alternating current motor has a voltage of 5 volts and a current of 3 amps. If the nameplate show that the motor has a power factor of 0.97, what is the power of the motor in watts?

$$\text{Watts} = (\text{volts})(\text{amps})(\text{power factor})$$

$$W = (5 \text{ volts})(3 \text{ amps})(0.97)$$

$$W = 14.55 \text{ watts}$$

# Force

...

# Force

- Force is a push or pull on an object resulting from the object's interaction with another object
- Measured in pounds (lbs)
- $1 \text{ psi} = 2.31 \text{ ft of head}$

$$\text{Force, lbs} = (\text{pressure, psi})(\text{area, in}^2)$$

$$F = P * A$$

TDEC - Fleming Training Center

## Force

- Pressure exerted on a surface corresponds to the force applied to the surface.
- Force = pressure x area

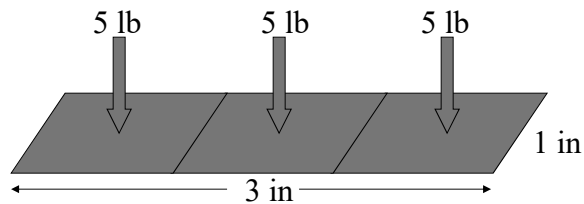

$$Force = (5 \text{ psi})(3 \text{ in})(1 \text{ in}) = 15 \text{ lb}$$

•27

## Example 8

- Determine the force, in lbs, being exerted on a surface that is 3 inches by 4 inches with 15 psi of pressure.

$$Force, \text{ lbs} = (\text{pressure, psi})(\text{area, in}^2)$$

$$Force, \text{ lbs} = (15 \text{ psi})(3 \text{ in})(4 \text{ in})$$

$$Force, \text{ lbs} = 180 \text{ lbs}$$

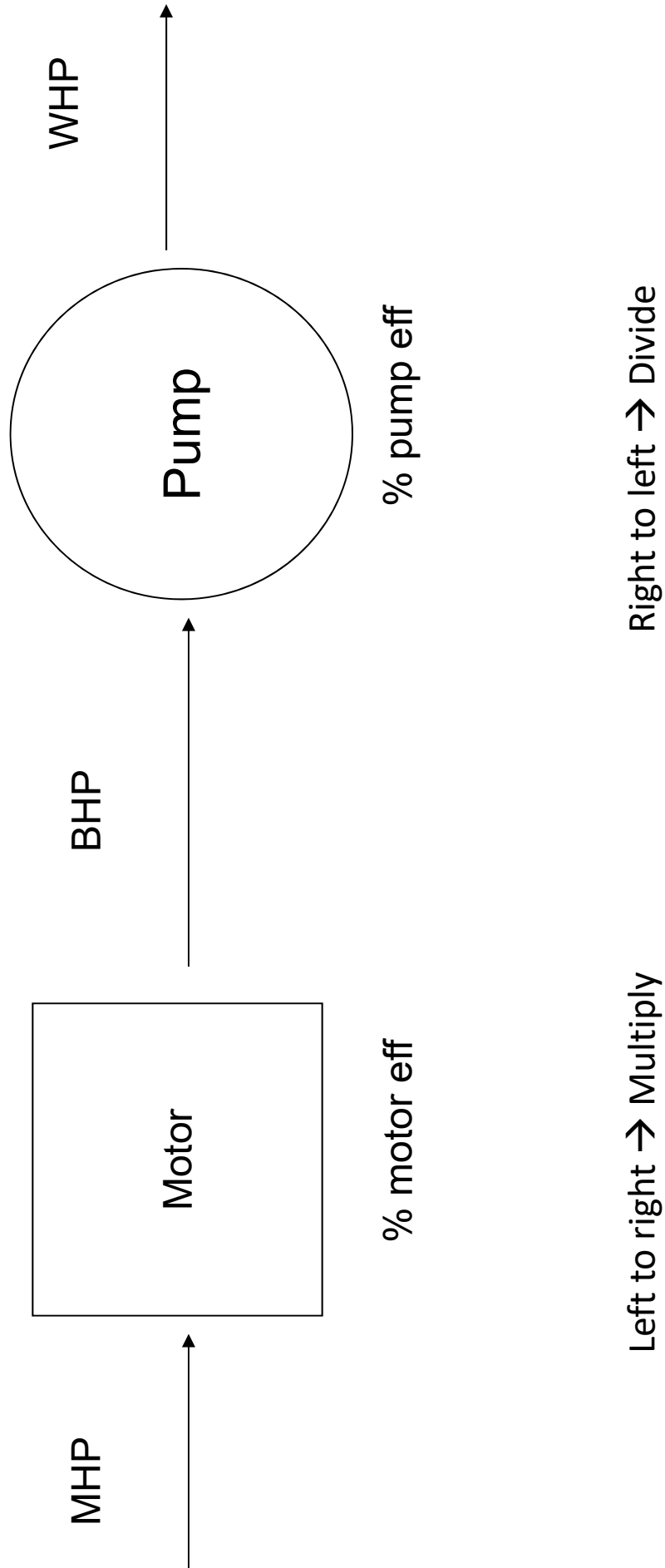



**Applied Math for Collection  
Pump Horsepower & Efficiency - Practice Quiz**

1. A pump must pump 2,500 gpm against a total head of 73 feet. What horsepower (water horsepower) will be required to do the work?
  
  
  
  
  
  
  
  
  
  
2. A pump is delivering a flow of 1,035 gpm against 46.7 feet of head. What horsepower will be required?
  
  
  
  
  
  
  
  
  
  
3. If a pump is to deliver 630 gpm of water against a total head of 102 feet, and the pump has an efficiency of 78%, what power must be supplied to the pump?
  
  
  
  
  
  
  
  
  
  
4. You have calculated that a certain pumping job will require 10.1 whp. If the pump is 84% efficient and the motor is 73% efficient, what motor horsepower will be required?

5. What is the wire to water efficiency if an electric power equivalent to 36 hp is supplied to the motor and 16.3 hp of work is accomplished?
6. A pump is discharging 1,250 gpm against a head of 71 feet. The wire-to-water efficiency is 82%. If the cost of power is \$0.028/kW hr, what is the cost of the power consumed during a week in which the pump runs 126 hours?.
7. A wet well is 12 feet long and 10 feet wide. The influent valve to the wet well is closed. If a pump lowers the water level 2.6 feet during a 5-minute pumping test, what is the gpm pumping rate?

## Answers:

- |    |          |    |            |
|----|----------|----|------------|
| 1. | 46.09 hp | 5. | 45.3%      |
| 2. | 12.2 hp  | 6. | \$71.95    |
| 3. | 20.80 hp | 7. | 466.75 gpm |
| 4. | 16.47 hp |    |            |

**Applied Math for Collection**  
**Pump Horsepower/Efficiency/Cost/Motors Problems**

**HORSEPOWER**

1. A pump must pump 3,000 gpm against a total head of 25 feet. What horsepower (water horsepower) will be required to do the work?
  
  
  
  
  
  
  
  
  
  
2. A flow of 555 gpm must be pumped against a head of 40 feet. What is the horsepower required?
  
  
  
  
  
  
  
  
  
  
3. Suppose a pump is pumping a total head of 76.2 feet. If 900 gpm is to be pumped, what is the water horsepower requirement?
  
  
  
  
  
  
  
  
  
  
4. Suppose a pump is pumping against a total head of 46 feet. If 850 gpm is to be pumped, what is the horsepower requirement?
  
  
  
  
  
  
  
  
  
  
5. A pump is delivering a flow of 835 gpm against a total head of 35.6 feet. What is the water horsepower?

6. What is the water horsepower of a pump that is producing 1,523 gpm against a head of 65 feet?

### **EFFICIENCY**

7. If a pump is to deliver 360 gpm of water against a total head of 95 feet, and the pump has an efficiency of 85 percent, what horsepower must be supplied to the pump?
8. If a pump is to deliver 450 gpm of water against a total head of 90 feet, and the pump has an efficiency of 70 percent, what horsepower must be supplied to the pump?
9. The motor nameplate indicated that the output of a certain motor is 35 hp. How much horsepower must be supplied to the motor, if the motor is 90% efficient?
10. The motor nameplate indicated that the output of a certain motor is 20 hp. How much horsepower must be supplied to the motor if the motor is 90 percent efficient?
11. You have calculated that a certain pumping job will require 9 whp. If the pump is 80 percent efficient and the motor is 72 percent efficient, what motor horsepower will be required?

12. You have calculated that a certain pumping job will require 6 whp. If the pump is 80 percent efficient and the motor is 90 percent efficient, what motor horsepower will be required?
  
  
  
  
  
  
  
  
  
  
13. Based on the gallons per minute to be pumped and the total head the pump must pump against, the water horsepower requirement was calculated to be 18.5 whp. If the motor supplies the pump with 21 hp, what must be the efficiency of the pump?
  
  
  
  
  
  
  
  
  
  
14. What is the wire to water efficiency if an electric power equivalent to 35 hp is supplied to the motor and 18.5 hp of work is accomplished?
  
  
  
  
  
  
  
  
  
  
15. Suppose that 31 kilowatts (kW) power is supplied to a motor. If the brake horsepower is 19 bhp, what is the efficiency of the motor?
  
  
  
  
  
  
  
  
  
  
16. Suppose that 10 kilowatts (kW) power is supplied to a motor. If the brake horsepower is 12 bhp, what is the efficiency of the motor?

**PUMPING COST**

17. The motor horsepower required for a particular pumping job is 39 hp. If your power cost is \$0.08/kW hr, what is the cost of operating the motor for one hour?
  
18. The motor horsepower required for a particular pumping job is 30 hp. If your power cost is \$0.05/kW hr, what is the cost of operating the motor for one hour?
  
19. You have calculated that the minimum motor horsepower requirement for a particular pumping problem is 25 mhp. If the cost of power is \$0.025/kW hr, what is the power cost in operating the pump for 14 hours?
  
20. A pump is discharging 1100 gpm against a head of 65 feet. The wire-to-water efficiency is 70 percent. If the cost of power is \$0.025/kW hr, what is the cost of the power consumed during a week in which the pump runs 80 hours?

21. Given a brake horsepower of 18.5, a motor efficiency of 88 percent and a cost of \$0.015/kW hr, determine the daily power cost for operating a pump.
  
  
  
  
  
  
  
  
  
  
22. A pump is discharging 1500 gpm against a head of 80 feet. The wire-to-water efficiency is 68 percent. If the cost of power is \$0.035/kW hr, what is the cost of the power consumed during a week in which the pump runs 90 hours?

### **MOTORS**

23. What would be the horsepower on a motor that is rated at 36 amps and 440 volts?
  
  
  
  
  
  
  
  
  
  
24. What would be the horsepower on a motor that is rated at 12 amps and 440 volts?
  
  
  
  
  
  
  
  
  
  
25. What would be the horsepower on a motor that is rated at 16 amps and 440 volts?

26. How many watts of power does a single-phase motor use if it pulls 12 amps at 110 volts and has a power factor of 1?
  
  
  
  
  
  
  
  
  
  
27. How many watts of power does a single-phase motor use if it pulls 12 amps at 220 volts and has a power factor of 0.8?
  
  
  
  
  
  
  
  
  
  
28. How many watts of power does a single-phase motor use if it pulls 12 amps at 110 volts and has a power factor of 0.3?
  
  
  
  
  
  
  
  
  
  
29. What is the power factor on a system that uses 3872 watts and pulls 11 amps at 440 volts?
  
  
  
  
  
  
  
  
  
  
30. What is the power factor on a system that uses 3960 watts and pulls 10 amps at 440 volts?



Answers:

**HORSEPOWER**

1. 18.9 hp
2. 5.6 hp
3. 17.3 hp
4. 9.9 hp
5. 7.5 hp
6. 25 hp

**EFFICIENCY**

7. 10.2 hp
8. 14.6 hp
9. 38.9 hp
10. 22.2 hp
11. 15.6 hp
12. 8.3 hp
13. 88%
14. 53%
15. 45.7%
16. 89.5%

**PUMPING COST**

17. \$2.33/hr
18. \$1.12/hr
19. \$6.53
20. \$38.48
21. \$5.76
22. \$104.72

**MOTORS**

23. 21.2 hp
24. 7.1 hp
25. 9.4 hp
26. 1,320 watts
27. 2,112 watts
28. 396 watts
29. 0.8
30. 0.9

**Applied Math for Collections**  
**Pump Rates Problems**

1. During a 60-minute pumping test, 9,456 gallons are pumped into a tank that has a length of 10 feet, width of 8 feet, and depth of 6 feet. The tank was empty before the pumping test was started. What is the GPM rate?
  
  
  
  
  
  
  
  
  
  
2. During a 30-minute pumping test, 3680 gallons are pumped into a tank, which has a diameter of 10 ft. The water level before the pumping test was 3 ft. What is the GPM rate?
  
  
  
  
  
  
  
  
  
  
3. A 50-ft diameter tank has water to a depth of 6 feet. The inlet valve is closed and a 2-hour pumping test is begun. If the water level in the tank at the end of the test is 2.3 feet, what is the pumping rate in gallons per minute?

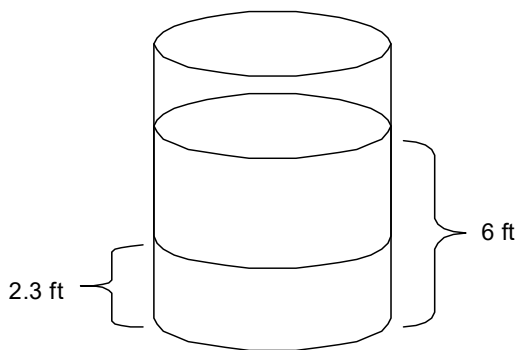





## **Section 10**

### **Laboratory**

Applied Math for Wastewater Systems

# LABORATORY CALCULATIONS

## Sampling

- ◎ Grab Sample = a single influent or effluent sample collected at a particular time
  
- ◎ Composite Sample = a combination of not less than 8 influent or effluent portions, of at least 100 mL, collected over a 24 hour period
  - Under certain circumstances a lesser time period may be allowed, but in no case, less than 8 hours.

$$\text{Composite Sample Single Portion} = \frac{(\text{Instantaneous Flow})(\text{Total Sample Volume})}{(\text{Number of Portions})(\text{Average Flow})}$$

## Temperature

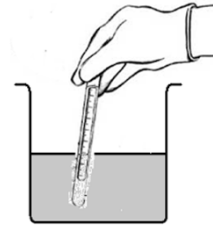

- ◎ Degrees Celsius =  $\frac{(^{\circ}\text{F} - 32)}{1.8}$
- ◎ Degrees Fahrenheit =  $(^{\circ}\text{C})(1.8) + 32$
  
- ◎ Example 1: Convert 45°C into Fahrenheit
  - Degrees F =  $(45)(1.8) + 32$
  - Degrees F = 113
- ◎ Example 2: Convert 95°F into Celsius
  - Degrees C =  $\frac{(95 - 32)}{1.8}$
  - Degrees C = 35

## Biochemical Oxygen Demand

- ◎ BOD is an indicator of the available food in the wastewater
- ◎ BOD test measures the amount of oxygen used by the microorganisms as they breakdown food (complex organic compounds) in the wastewater.
- ◎ DO is tested at beginning of test = Initial DO
- ◎ DO is tested at end of test = Final DO
- ◎ The BOD test is conducted on a diluted sample, therefore the percent dilution of the sample must be included in the calculation. (This is "P" and is expressed as a decimal.)

## Biochemical Oxygen Demand

### ◎ BOD QC Requirements:

- Blanks must not deplete more than 0.2 mg/L DO
- The sample must deplete at least 2.0 mg/L DO
  - If it does not, the dilution is too weak
  - Report as inadequate dilution
- After 5 days of incubation at 20°C +/- 1.0°C, the sample must have at least 1.0 mg/L DO remaining.
  - If it is less than 1.0 mg/L, the dilution was too strong



## Biochemical Oxygen Demand

### ◎ ABC Formula Book:

Unseeded:

$$\text{◎ BOD, mg/L} = \frac{\left[ \left( \text{Initial DO, } \frac{\text{mg}}{\text{L}} \right) - \left( \text{Final DO, } \frac{\text{mg}}{\text{L}} \right) \right] [300 \text{ mL}]}{\text{mL of Sample}}$$

Seeded:

$$\text{◎ BOD, mg/L} = \frac{\left[ \left( \text{Initial DO, } \frac{\text{mg}}{\text{L}} \right) - \left( \text{Final DO, } \frac{\text{mg}}{\text{L}} \right) - \text{Seed Correction factor, } \frac{\text{mg}}{\text{L}} \right] [300 \text{ mL}]}{\text{mL of Sample}}$$

- ◎ Note that the ABC formula does not use "P" because it factors the bottle volume and sample size into the equation



## Biochemical Oxygen Demand

- FTC Formula Book:

Unseeded:

- $BOD_5, \text{ mg/L} = \frac{D1 - D2}{P}$

Seeded:

- $BOD_5, \text{ mg/L} = \frac{(D1 - D2) - \overbrace{(B1 - B2)}^{\text{Seed Correction Factor}}}{P} f$

Where:

- D1 = Initial DO, mg/L
- D2 = Final DO, mg/L
- B1 = Initial DO in Seed Control, mg/L
- B2 = Final DO in Seed Control, mg/L
- P = Sample concentration, % (expressed as a decimal)
- $f = \frac{\text{Seed in Sample, \%}}{\text{Seed in Seed Control, \%}}$

$$P = \frac{\text{Volume of Sample}}{300 \text{ mL}}$$

## Biochemical Oxygen Demand

- *Example:* Given the following data, determine the BOD of the wastewater:

- Sample volume = 4 mL
- BOD bottle volume = 300 mL
- Initial DO of diluted Sample = 7 mg/L
- Final DO of diluted sample = 4 mg/L

- $BOD, \text{ mg/L} = \frac{\left[ \left( \text{Initial DO, } \frac{\text{mg}}{\text{L}} \right) - \left( \text{Final DO, } \frac{\text{mg}}{\text{L}} \right) \right] [300 \text{ mL}]}{\text{mL of Sample}}$

- $BOD, \text{ mg/L} = \frac{[(7 \text{ mg/L}) - (4 \text{ mg/L})][300 \text{ mL}]}{4 \text{ mL of Sample}}$

- $BOD = 225 \text{ mg/L}$

## BOD 7 Day Average

- ⦿ The BOD of wastewater varies from day to day, maybe even hour to hour.
- ⦿ Operational control often based on trends in data
  - Rather than individual data points
- ⦿ Moving Average: a new 7 day average is calculated each day
  - Adding the new days value and the 6 previous days values

BOD 7-DAY MOVING AVERAGE

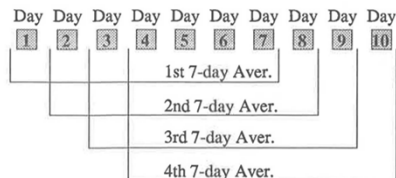

$$\text{7-day Aver. BOD} = \frac{\text{BOD}_{\text{Day 1}} + \text{BOD}_{\text{Day 2}} + \text{BOD}_{\text{Day 3}} + \text{BOD}_{\text{Day 4}} + \text{BOD}_{\text{Day 5}} + \text{BOD}_{\text{Day 6}} + \text{BOD}_{\text{Day 7}}}{7}$$

## BOD 7 Day Average

- ⦿ *Example:* Given the following primary effluent BOD test results, calculate the 7-day average.
  - May 1 – 210 mg/L
  - May 2 – 218 mg/L
  - May 3 – 202 mg/L
  - May 4 – 207 mg/L
  - May 5 – 224 mg/L
  - May 6 – 216 mg/L
  - May 7 – 220 mg/L

- ⦿ 7 Day Avg BOD =  $\frac{210+218+202+207+224+216+220}{7}$

- ⦿ 7 Day Avg BOD = 214 mg/L

## Settleable Solids (Imhoff Cone)

- ◎ 1 Liter sample collected from Clarifier influent and effluent
- ◎ Conducted in a 1 liter Imhoff Cone
- ◎ 60 minute test
  - Solids settle for 45 minutes
  - Then gently stir sides
  - Allow solids to settle for another 15 minutes
- ◎ By running on wastewater influent and effluent, this test can estimate the % removal of settleable solids

## Settleable Solids (Imhoff Cone)

- ◎ % Removal of Settleable Solids = 
$$\frac{\text{Settleable Solids Removed, mL/L}}{\text{Settleable Solids in Influent, mL/L}} \times 100$$

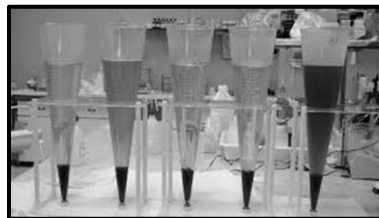
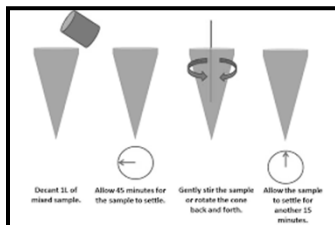

## Settleable Solids (Imhoff Cone)

- ◎ *Example 1:* Calculate the % removal of settleable solids if the settleable solids of the sedimentation tank influent is 17 mL/L and the settleable solids of the effluent is 0.3 mL/L.
- ◎ % Removal of Settleable Solids =
 
$$\frac{\text{Settleable Solids Removed, mL/L}}{\text{Settleable Solids in Influent, mL/L}} \times 100$$
- ◎ % Removal of Settleable Solids =  $\frac{16.7 \text{ mL/L}}{17.0 \text{ mL/L}} \times 100$
- ◎ = 98% Settleable Solids Removed

## Settleability

- ◎ An activated sludge sample is taken from the aeration basin
- ◎ Poured into a 2000 mL Mallory Settleometer
- ◎ Allowed to settle for 60 minutes
- ◎ Settling characteristics give an indication of the settling characteristics of the MLSS in the secondary clarifier
- ◎ “Benchtop Clarifier”

## Settleability

$$\odot \text{ \% Settleable Solids} = \frac{\text{mL Settled Solids}}{2000 \text{ mL Sample}} \times 100$$

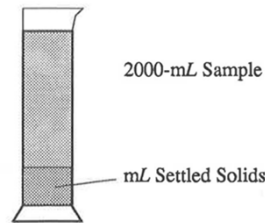

## Settleability

- ◉ *Example 1:* The settleability test is conducted on an MLSS sample. What is the percent settleable solids if 380 mL settle?

$$\odot \text{ \% Settleable Solids} = \frac{\text{mL Settled Solids}}{2000 \text{ mL Sample}} \times 100$$

$$\odot \text{ \% Settleable Solids} = \frac{380 \text{ mL}}{2000 \text{ mL Sample}} \times 100$$

$$\odot = 19 \text{ \% Settleable Solids}$$

## Sludge Volume Index

- ⦿ Describes the ability of the sludge to settle and compact.
- ⦿ SVI gives a more accurate picture of the sludge settling characteristics than settleability or MLSS alone.
- ⦿ SVI can indicate changes occurring in the activated sludge treatment process.
- ⦿ By trending SVI data over a period of time, operators are able to prevent problems.

## Sludge Volume Index

- ⦿ 
$$\text{SVI, mL/g} = \frac{(\text{SSV}_{30}, \text{mL/L})(1,000 \text{ mg/g})}{\text{MLSS, mg/L}}$$
- ⦿ *Example:* If  $\text{SSV}_{30}$  is 210 mL and MLSS concentration is 2200 mg/L, what is the SVI?
- ⦿ 
$$\text{SVI, mL/g} = \frac{(\text{SSV}_{30}, \text{mL/L})(1,000 \text{ mg/g})}{\text{MLSS, mg/L}}$$
- ⦿ 
$$\text{SVI, mL/g} = \frac{(210 \text{ mL/L})(1,000 \text{ mg/g})}{2200 \text{ mg/L}}$$
- ⦿ 
$$\text{SVI} = 95$$

## Sludge Density Index

- ◎ SDI is used in a similar way to the SVI to indicate the settleability of a sludge in the final clarifier.
- ◎ SDI = the weight in mg of 1 mL of MLSS after 30 minutes of settling.
  - Incorporates the SVI value
- ◎  $SDI = \frac{100}{SVI}$

## Sludge Density Index

- ◎ *Example:* The MLSS concentration in an aeration tank is 3300 mg/L. If the  $SSV_{30}$  is 313 mL, what is the SDI?
- ◎ First, you must find the SVI:
  - $SVI, \text{ mL/g} = \frac{(SSV_{30}, \text{ mL/L})(1,000 \text{ mg/g})}{MLSS, \text{ mg/L}}$
  - $SVI, \text{ mL/g} = \frac{(313 \text{ mL/L})(1,000 \text{ mg/g})}{3300 \text{ mg/L}}$
  - $SVI = 95$
- ◎ Then use that number to find the SDI:
  - $SDI = \frac{100}{SVI}$
  - $SDI = \frac{100}{95}$
  - $SDI = 1.05$

## Solids

- Wastewater is comprised of both water and solids
  - Most suspended solids are organic
- Total Solids
  - All residue left after drying
- Dissolved Solids (TDS)
  - The portion of TS which pass through a 2.0um filter
- Suspended Solids (TSS)
  - The portion retained on the 2.0um filter
- Fixed Solids
  - The portion of TS, DS, TSS which remains after ignition at 550°C
- Volatile Solids
  - The portion which burns away at 550°C

## Solids

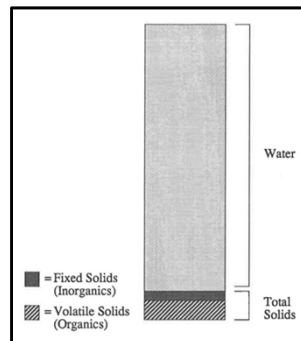
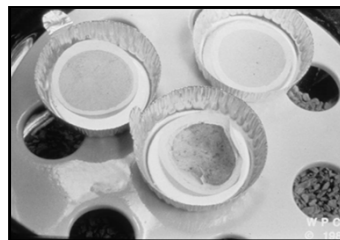
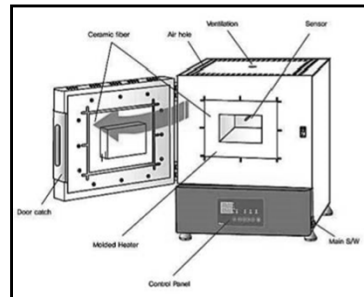



## Solids – Total Solids

### ☉ Total Solids

- Pipet sample into evaporating dish and put in 103-105°C oven for 1 hour

$$\text{☉ Total Solids, mg/L} = \frac{(A - B)(1,000,000)}{\text{Sample Volume, mL}}$$

- Where: A = Weight of dish and dried solids in grams  
B = Weight of dish in grams

ABC formula book:

$$\text{☉ Total Solids, \%} = \frac{(\text{Dried weight, g}) - (\text{Tare weight, g})(100)}{(\text{Wet weight, g}) - (\text{Tare weight, g})}$$

## Solids - TSS

### ☉ Total Suspended Solids (TSS)

- Suspended solids trapped on a filter and dried in 103-105°C oven

$$\text{☉ TSS, mg/L} = \frac{(A - B)(1,000,000)}{\text{Sample Volume, mL}}$$

- Where: A = Final weight of dish, filter, and residue in grams  
B = Weight of prepared filter and dish in grams

## Solids- TSS

- ◎ *Example:* Given the following information, calculate the mg/L suspended solids of the sample.
  - Weight of sample and dish (after drying in 103-105°C oven) = 24.6862 g
  - Weight of dish = 24.6820 g
  - Sample volume = 50 mL
- ◎  $TSS, \text{ mg/L} = \frac{(A - B)(1,000,000)}{\text{Sample Volume, mL}}$
- ◎  $TSS, \text{ mg/L} = \frac{(24.6862\text{g} - 24.6820\text{g})(1,000,000)}{50 \text{ mL}}$
- ◎  $TSS, \text{ mg/L} = \frac{4200}{50}$
- ◎  $TSS = 84 \text{ mg/L}$

## Solids – Fixed and Volatile Solids

- ◎ Ignite filter with residue (from TSS test) in 550°C muffle furnace
  - Remaining solids represent the fixed TS, TDS, or TSS
  - Weight lost on ignition represents the Volatile solids
- ◎ Volatile Solids,  $\text{mg/L} = \frac{(A - B)(1,000,000)}{\text{Sample Volume, mL}}$ 
  - Where: A = Weight of dish and dried solids in grams  
B = Weight of dish and ash in grams
- ◎ Fixed Solids,  $\text{mg/L} = \frac{(C - B)(1,000,000)}{\text{Sample Volume, mL}}$ 
  - Where: B = Weight of dish and ash in grams  
C = Weight of dish in grams

## Alkalinity

- ⦿ Defined as the measurement of a water's capacity to neutralize an acid
- ⦿ Buffering capacity = ability to resist a change in pH
- ⦿ An acid releases  $H^+$ , alkalinity in water will absorb the  $H^+$
- ⦿ Reported in terms of equivalent calcium carbonate ( $CaCO_3$ )
- ⦿ Nitrification
  - 7.1 mg/L alkalinity consumed for every 1 mg/L ammonia oxidized
- ⦿ Denitrification
  - 3.6 mg/L alkalinity recovered

## Alkalinity

- ⦿ Total Alkalinity
  - Titration
  - pH endpoint of 4.5

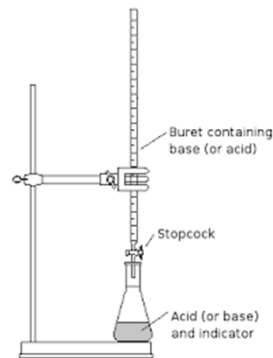

$$\text{Total Alk, mg/L as } CaCO_3 = \frac{(\text{Titrant Volume, mL})(\text{Acid Normality})(50,000)}{\text{Sample volume, mL}}$$

- The titrant will be the amount of sulfuric acid used to reach a pH of 4.5
- Acid normality =  $0.02N H_2SO_4$

## Alkalinity

- Example: A 100 mL sample was titrated using a buret and 0.02N sulfuric acid. It took 25 mL to reach the pH endpoint of 4.5. What is the total alkalinity of the sample?
- Total Alk, mg/L as  $\text{CaCO}_3$  = 
$$\frac{(\text{Titrant Volume, mL})(\text{Acid Normality})(50,000)}{\text{Sample volume, mL}}$$
- Total Alk, mg/L as  $\text{CaCO}_3$  = 
$$\frac{(25 \text{ mL})(0.02\text{N})(50,000)}{100 \text{ mL}}$$
- Total Alkalinity = 250 mg/L as  $\text{CaCO}_3$

## Molarity

- A solution is comprised of 2 parts:
  - A Solvent = the dissolving medium (Ex: water)
  - A Solute = the substance dissolved
- The main methods of expressing solution concentrations are:
  - % strength
  - Molarity
  - Normality

## Molarity

- ⦿ A solution of one molarity = one mole of the solute dissolved in one liter

- ⦿ 
$$\text{Molarity} = \frac{\text{Moles of Solute}}{\text{Liters of Solute}}$$

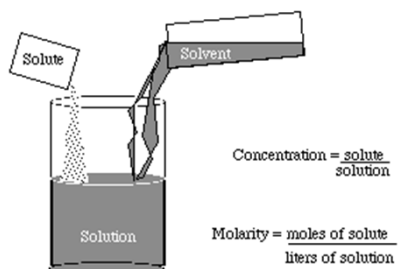

- ⦿ 
$$\text{Number of Moles} = \frac{\text{Total Weight}}{\text{Molecular Weight}}$$

## Molarity

- ⦿ Example: If 2.5 moles of solute are dissolved in 0.5 liters of solution, what is the molarity of the solution?

- ⦿ 
$$\text{Molarity} = \frac{\text{Moles of Solute}}{\text{Liters of Solute}}$$

- ⦿ 
$$\text{Molarity} = \frac{2.5}{0.5}$$

- ⦿ 
$$\text{Molarity} = 5$$

- ⦿ Called 5 Molarity or a 5-Molar Solution
- ⦿ 5M

## Normality

- ⦿ The molarity of a solution refers to its concentration, whereas the **normality** of the solution refers to the reacting power of the solution.
- ⦿ Normality = a measure of the “reacting power” of a solution
- ⦿ Based on the concept of equivalent weights
  - A specific number of equivalents of one substance will react with the same number of equivalents of another substance.
  - For example, if one equivalent of Substance A is mixed with 2 equivalents of Substance B, only one equivalent of each substance will react, leaving an excess of one equivalent of Substance B.

## Normality

- ⦿ Normality = 
$$\frac{\text{Number of Equivalents of Solute}}{\text{Liters of Solution}}$$
- ⦿ Number of Equivalent Weights = 
$$\frac{\text{Total Weight}}{\text{Equivalent Weight}}$$
  - Total weight is the weight of chemical in grams
  - Equivalent weight = 
$$\frac{\text{Atomic weight}}{\text{Net valence}}$$
    - Net valence is the number of valence electrons

## Normality

- ⦿ *Example 1:* If 2.5 equivalents of a chemical are dissolved in 1.5 liters solution, what is the normality of the solution?
- ⦿ Normality =  $\frac{\text{Number of Equivalents of Solute}}{\text{Liters of Solution}}$
- ⦿ Normality =  $\frac{2.5 \text{ Equivalents}}{1.5 \text{ Liters}}$
- ⦿ Normality = 1.67N

## Normality

- ⦿ *Example 2:* The molecular weight of  $\text{Na}_2\text{CO}_3$  is 106. The net valence is 2. If 90 grams of  $\text{Na}_2\text{CO}_3$  are dissolved in a solution, how many equivalents are dissolved in the solution?
- ⦿ The equivalent weight of  $\text{Na}_2\text{CO}_3$  is  $106/2 = 53$ . Calculate the number of equivalents as follows:
- ⦿ Number of Equivalent Weights =  $\frac{\text{Total Weight}}{\text{Equivalent Weight}}$
- ⦿ Number of Equivalent Weights =  $\frac{\text{grams of Na}_2\text{CO}_3}{\text{Equivalent weight}}$
- ⦿ Number of Equivalent Weights =  $\frac{90 \text{ grams}}{53 \text{ grams/equivalent}}$
- ⦿ Number of Equivalent Weights = 1.7

## Normality

- ⊙ The normality equation can be re-arranged as:
  - (Normality of Soln)(Liters of Soln) = Equivalents in Solution
  - Because chemicals react on the basis of equivalents, this relationship is important to understanding titrations.
    - Millequivalent = (mL)(Normality)
- ⊙ In general, where N = normality of the solution and V = volume of the solution
  - $N_1V_1 = N_2V_2$

## Normality

- ⊙ *Example 3:* How many milliliters of 0.5N NaOH will react with 500 mL of 0.01N HCl?

- ⊙  $N_1V_1 = N_2V_2$  ← “Two Normal” Equation

- ⊙  $(0.5)(x \text{ mL}) = (0.01)(500 \text{ mL})$

- ⊙  $0.5x = 5$

- ⊙  $\frac{0.5x}{0.5} = \frac{5}{0.5}$

- ⊙  $X = 10 \text{ mL NaOH}$

How to mix a Standard Solution

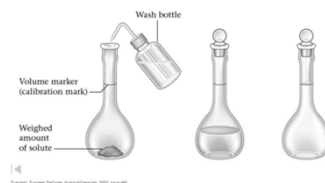



## Making standards

- ⦿ *Example:* You need 100 mL of 0.02N H<sub>2</sub>SO<sub>4</sub> to conduct an alkalinity titration. If you only have 5N H<sub>2</sub>SO<sub>4</sub> in the lab, how many mL of that will it take to get your desired concentration?
- ⦿  $C_1V_1 = C_2V_2$
- ⦿  $(5)(x \text{ mL}) = (0.02)(100 \text{ mL})$
- ⦿  $5x = 2 \text{ mL}$
- ⦿  $\frac{5x}{5} = \frac{2 \text{ mL}}{5}$
- ⦿  $x = 0.4 \text{ mL of } 5\text{N H}_2\text{SO}_4$

## Bacterial Analysis

- ⦿ Geometric Mean
  - All the results from that month
  - NOT an average
- ⦿ Fecal Coliform
  - Incubated at 44.5 +/- 0.2°C
  - Ideal sample volume yields 20-60 colonies
- ⦿ E.coli
  - Incubated at 35.0 +/- 0.5°C
  - Ideal sample volume yields 20-80 colonies

## Bacterial Analysis

- Select the petri dishes/filters with acceptable colony counts only
- If counts are within acceptable limits:

- $\#CFU/100 \text{ mL} = \frac{(\# \text{ of Colonies on Plate})(100)}{\text{mL of Sample}}$

## Bacterial Analysis

- *Example:* Given the following mColi Blue results, calculate the number of bacterial colonies per 100 mL of water.

| Filtration Volume | Colony Counts |
|-------------------|---------------|
| 15 ml             | 110           |
| 5 ml              | 40            |
| 1.5 ml            | 10            |
| 0.5 ml            | 5             |

- $\#CFU/100 \text{ mL} = \frac{(\# \text{ of Colonies on Plate})(100)}{\text{mL of Sample}}$
- $\#CFU/100 \text{ mL} = \frac{(40)(100)}{5 \text{ mL}}$
- $\#CFU/100 \text{ mL} = 800$

## Geometric Mean

- ⦿ Geometric mean is a mean or average, which indicates the central tendency or typical value of a set of numbers by using the product of their values.
  - NPDES definition: any set of values is the  $n^{\text{th}}$  root of the product of the individual values where “n” is equal to the number of individual values
- ⦿ Geometric mean =  $(x_1)(x_2)(x_3)\dots(x_n)^{1/n}$ 
  - n = the number of results
    - Ex: the number of bacterial results you have for the month
- ⦿ Any zeros are converted to a 1

## Geometric Mean

- ⦿ *Example:* A WWTP is required by their NPDES permit to collect 3 E.coli samples per week. Given the following test results, calculate the monthly geometric mean.

|         |          |
|---------|----------|
| Week 1: | 5,10,7   |
| Week 2: | 0,0,11   |
| Week 3: | 13,97,89 |
| Week 4: | 53,17,5  |

- ⦿ Step 1: Find  $1/n$ 
  - We have 12 sample results, thus  $n = 12$
  - $1/12 = 0.0834$
- ⦿ Step 2: Multiply all sample result numbers together and punch the “=” button on your calculator
  - $5 \times 10 \times 7 \times 1 \times 1 \times 11 \times 13 \times 97 \times 89 \times 53 \times 17 \times 5 = 1.94\dots \text{E}12$
  - Leave this number pulled up on the calculator
- ⦿ Step 3: Press the “ $y^x$ ” (or “ $\wedge$ ”) button and then type in the number from Step 1
  - $1.94\dots \text{E}12^{0.0834} = 10.59$

## Oxygen Uptake Rate

- ⦿ The rate at which biomass is using oxygen
- ⦿ Grab sample in 300 mL BOD bottle
- ⦿ Take DO readings every 1 min for 15 min (or until DO drops to 1 mg/L)
  - After meter reading has stabilized, record initial DO and start timing device – SM 2710 B(3)(d)(3)
- ⦿ OUR, mg O<sub>2</sub>/L/min =  $\frac{\text{Initial DO} - \text{Ending DO}}{\text{Elapsed Time}}$
- ⦿ OUR, mg O<sub>2</sub>/L/min x 60 min/hr = OUR, mg O<sub>2</sub>/L/hr

## OUR

- ⦿ *Example 1:* Determine the OUR based on the data in the table.

- ⦿ OUR, mg O<sub>2</sub>/L/min =  $\frac{\text{Initial DO} - \text{Ending DO}}{\text{Elapsed Time}}$

- ⦿ OUR, mg O<sub>2</sub>/L/min =  $\frac{6.50 \text{ mg/L} - 3.50 \text{ mg/L}}{3 \text{ min}}$

- ⦿ OUR, mg O<sub>2</sub>/L/min = 1 mg O<sub>2</sub>/L/min

- ⦿ 1 mg O<sub>2</sub>/L/min x 60 min/hr = 60 mg O<sub>2</sub>/L/hr

|             |           |
|-------------|-----------|
| Initial DO: | 7.20 mg/L |
| Minute 1:   | 6.95 mg/L |
| Minute 2:   | 6.50 mg/L |
| Minute 3:   | 5.50 mg/L |
| Minute 4:   | 4.40 mg/L |
| Minute 5:   | 3.50 mg/L |
| Minute 6:   | 2.50 mg/L |
| Minute 7:   | 0.95 mg/L |

Start to see fairly consistent DO change here

Just before consistency in DO values change

## Specific Oxygen Uptake Rate

- ◎ Also called Respiration Rate
  - Now used as an alternative test method to meet the vector attraction reduction requirement for 40 CFR 503 (Biosolids)
    - 0400-40-15-.04 (4)(b)(4): “the specific oxygen uptake rate (SOUR) for biosolids treated in an aerobic process shall be equal to or less than 1.5 milligrams of oxygen per hour per gram of total solids (dry weight basis) at a temperature of 20°Celsius.”
- ◎ 
$$\text{SOUR, mg O}_2/\text{hr/gm MLVSS} = \frac{(\text{OUR, mg O}_2/\text{L/hr} \times 1000\text{mg/gm})}{\text{MLVSS, mg/L}}$$

### ABC Formula Book:

- ◎ 
$$\text{SOUR, mg O}_2/\text{hr/gm MLVSS} = \frac{\text{OUR, (mg O}_2/\text{L)/min(60 min)}}{\text{MLVSS, g/L(1 hr)}}$$

## Reference:

- ◎ Applied Math for Wastewater Plant Operators by Joanne Kirkpatrick Price  
Technomic Publishing Company, Inc  
1991

Any Questions?



## Applied Math for Wastewater Treatment Geometric Mean

### Geometric Mean Using a Texas Instrument TI-30Xa

Example:

60            100            0            0

Geometric Mean –  $(X_1)(X_2)(X_3)...(X_n)^{1/n}$

Step 1:  $1/n \rightarrow 1$  divided by the number of test results. For our example above, there are four test results.

- $1 \div 4 = 0.25$  (write this number down, you will use it in Step 3)

Step 2: Multiply all of the test results together and punch the = button on the calculator. Remember to count 0 as a 1.

- $60 \times 100 \times 1 \times 1 = 6000$  (Do Not clear out your calculator)

Step 3: Punch the  $y^x$  button and then type in the number from Step 1, then punch =.

- $6000 y^x 0.25 = 8.8011$



### Geometric Mean Using a Texas Instrument TI-30XIIB

Example:

60            100            0            0

Geometric Mean –  $(X_1)(X_2)(X_3)...(X_n)^{1/n}$

Step 1:  $1/n \rightarrow 1$  divided by the number of test results. For our example above, there are four test results.

- $1 \div 4 = 0.25$  (write this number down, you will use it in Step 3)

Step 2: Multiply all of the test results together and punch the = button on the calculator. Remember to count 0 as a 1.

- $60 \times 100 \times 1 \times 1 = 6000$  (Do Not clear out your calculator)

Step 3: Punch the  $\wedge$  button, then type in the number from Step 1, & then punch =.

- $6000 y^x 0.25 = 8.8011$

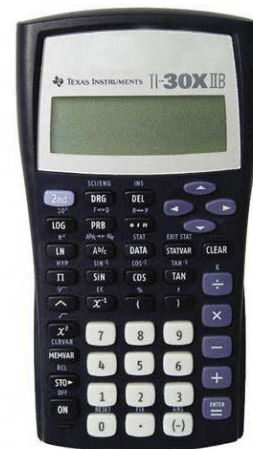

## Applied Math for Wastewater Treatment Laboratory

### Sampling

1. To determine the average turbidity coming into a plant, an operator collects 5 samples to combine into a 250 mL composite sample. The average flow at the intake is 230,000 gpd. If the flow at the time of the sample collection is 180 gpm, how many mL should the sample portion be at the time of collection?

### Temperature

2. Convert 45 degrees Fahrenheit to degrees Celsius.
3. Convert 32 degrees Celsius in to Fahrenheit.

### Biochemical Oxygen Demand (BOD), mg/L

4. Given the following information, determine the BOD of the wastewater:  
[Unseeded]  
Sample Volume = 5 mL  
BOD Bottle Volume = 300 mL  
Initial DO of Diluted Sample = 6 mg/L  
Final DO of Diluted Sample = 3.5 mg/L



5. Given the following information, determine the BOD of the wastewater:  
[Seeded]  
Sample Volume = 10 mL  
BOD Bottle Volume = 300 mL  
Initial DO of Diluted Sample = 8.3mg/L  
Final DO of Diluted Sample = 4.2 mg/L  
Seed Correction Factor = 0.75 mg/L

### **7 Day Average**

6. Given the following primary effluent BOD test results, calculate the 7-day average:

April 10 – 190 mg/L  
April 11 – 198 mg/L  
April 12 – 205 mg/L  
April 13 – 202 mg/L  
April 14 – 210 mg/L  
April 15 – 201 mg/L  
April 16 – 197 mg/L

### **Settleable Solids (Imhoff Cone)**

7. Calculate the percent removal of settleable solids if the settleable solids of the sedimentation tank influent are 16.5 mL/L and the settleable solids of the effluent are 0.6 mL/L.

### **Settleability**

8. The settleability test is conducted on a sample of MLSS. What is the percent settleable solids if 410 mL settle in the 2000-mL graduate?

**Sludge Volume Index (SVI)**

9. The activated sludge settleability test indicates 380 mL settling in the 2-liter graduate cylinder. If the MLSS concentration in the aeration tank is 2260 mg/L, what is the sludge volume index?

**Sludge Density Index (SDI)**

10. The MLSS concentration in the aeration tank is 2050 mg/L. If the activated sludge settleability test indicates 219 mL settled in the one-liter graduated cylinder, what is the sludge density index?

**Suspended Solids and Volatile Suspended Solids**

11. Given the following information regarding a primary effluent sample, calculate (a) the mg/L suspended solids and (b) the percent volatile suspended solids of the sample.

| Sample Volume = 50 mL     | After Drying<br>(Before Burning) | After Burning<br>(Ash) |
|---------------------------|----------------------------------|------------------------|
| Weight of Sample & Dish   | 25.6715 g                        | 25.6701 g              |
| Weight of Dish (Tare Wt.) | 25.6670 g                        | 25.6670 g              |

**Alkalinity**

12. Calculate the total alkalinity in mg/L as  $\text{CaCO}_3$  for a sample of raw wastewater that required 24 mL of 0.02N  $\text{H}_2\text{SO}_4$  to titrate 100 mL sample from pH 7.2 to 4.5.

**Molarity**

13. What is the molarity of a solution that has 0.4 moles solute dissolved in 1250 mL solution?
14. The atomic weight of calcium is 40. If 65 grams of calcium are used in making up a one liter solution, how many moles are used?

**Normality**

15. If 1.5 equivalents of a chemical are dissolved in 3.5 liters solution, what is the normality of the solution?
16. The molecular weight of  $\text{Na}_2\text{CO}_3$  is 106 and the net valence is 2. If 67 grams of  $\text{Na}_2\text{CO}_3$  are dissolved in a solution, how many equivalents are dissolved in the solution?

**Solutions, Making Standards**

17. How many mL of 0.7 N NaOH is needed to get 750 mL of 0.05 N NaOH?
18. QC requirements for the SM 4500 P B test include a lab fortified blank that goes through digestion. The LFB concentration should be 0.5 mg/L. How many mL of 50 mg/L concentration PO<sub>4</sub> standard will be needed to make 100 mL of 0.5 mg/L concentration?

**Bacteriological, fecal coliform and *E. coli***

19. Three different volumes of an effluent sample were tested for fecal coliform. Calculate the number of CFU per 100 mL of sample.

|               | Filter # 1 | Filter # 2 | Filter # 3 |
|---------------|------------|------------|------------|
| Sample Volume | 25 mL      | 10 mL      | 5 mL       |
| Colony Count  | 108        | 51         | 5          |

20. Given the following mColi Blue results, calculate the number of bacterial colonies per 100 mL of water.

| Filtration Volume | Colony Count |
|-------------------|--------------|
| 50 mL             | 64           |
| 25 mL             | 32           |
| 10 mL             | 16           |

### **Geometric Mean**

21. Determine the geometric mean for the following samples:

- Sample #1 = 20.0 mg/L
- Sample #2 = 20.0 mg/L
- Sample #3 = 210.0 mg/L
- Sample #4 = 3,500.0 mg/L

22. Calculate the geometric mean for the following fecal coliform test results: 0, 0, 50, 50, 25, 100, 100, 50, 75, 50

**Oxygen Uptake Rate (OUR)**

23. Dissolved air concentrations are taken on an air-saturated sample of digested aerobic sludge at one-minute intervals. Given the following results, calculate the oxygen uptake rate, mg/L/hr.

| Elapsed Time, min | DO, mg/L |
|-------------------|----------|
| 0                 | 7.9      |
| 1                 | 6.8      |
| 2                 | 6.1      |
| 3                 | 5.3      |
| 4                 | 4.6      |
| 5                 | 3.9      |

**Specific Oxygen Uptake Rate (SOUR)**

24. Using the OUR result from #23 above, calculate the specific oxygen uptake rate (SOUR) if the mixed liquor volatile suspended solids concentration is 1600 mg/L.

**Answers:**

- |                   |                                |                                   |
|-------------------|--------------------------------|-----------------------------------|
| 1. 56.35 mL       | 9. 84.07 mL/g                  | 17. 53.6 mL                       |
| 2. 7.22 degrees C | 10. 0.9361                     | 18. 1 mL                          |
| 3. 89.6 degrees F | 11. (a) 90 mg/L, (b) 31.11%    | 19. 510 cfu/100 mL                |
| 4. 150 mg/L       | 12. 240 mg/L CaCO <sub>3</sub> | 20. 128 cfu/100 mL                |
| 5. 100.5 mg/L     | 13. 0.32 Molarity              | 21. 130.94                        |
| 6. 200.43 mg/L    | 14. 1.6 moles                  | 22. 25.52                         |
| 7. 96.36 %        | 15. 0.43 N                     | 23. 44 mg/L/hr                    |
| 8. 20.5 %         | 16. 1.26                       | 24. 27.5 mg O <sub>2</sub> /hr/gm |

## Applied Math for Wastewater Treatment Laboratory - Additional Problems

### Sampling

1. The average flow through a wastewater plant is 3.5 MGD. A flow-proportional composite sampler is set to collect 8 samples to create a total sample volume of 1500 mL. If the flow at the time of sample collection was 3.31 MGD, calculate the volume of a single portion of the composite sample.
2. A wastewater laboratory requires 1.5 L of composited sample to conduct their daily tests so they set up a flow-proportional composite sampler to collect 12 samples over a 24 hour period for the total volume they need. The average influent flow to their plant is 4,250,000 gal, but the flow at the time of sample collection was 3.9 MGD.

### Temperature

3. The influent to a treatment plant has a temperature of 70°F. What is the temperature expressed in degrees Celsius?
4. The effluent of a treatment plant is 24°C. What is the temperature expressed in degrees Fahrenheit?
5. The influent to a treatment plant has a temperature of 77°F. What is this temperature expressed in degrees Celsius?
6. Convert 60°F to degrees Celsius.

7. The effluent of a treatment plant is 24°C. What is this temperature expressed in degrees Fahrenheit?
8. What is 16°C expressed in terms of degrees Fahrenheit?

### **Biochemical Oxygen Demand (BOD), mg/L**

9. Given the following information, determine the BOD of the wastewater after 5 days:

[Unseeded]

Sample Volume = 7 mL

BOD Bottle Volume = 300 mL

Initial DO of Diluted Sample = 8 mg/L

Final DO of Diluted Sample = 3.7 mg/L

10. Results from a BOD test are provided. Calculate the BOD of the sample after 5 days:

[Seeded]

Sample Volume = 12 mL

BOD Bottle Volume = 300 mL

Initial DO of Diluted Sample = 8.7 mg/L

Final DO of Diluted Sample = 4.4 mg/L

Seed Correction Factor = 0.98 mg/L

### **7 Day Average**

11. Given the following primary effluent BOD test results, calculate the 7-day average:

April 10 – 220 mg/L

April 14 – 112 mg/L

April 11 - 315 mg/L

April 15 - 255 mg/L

April 12 - 265 mg/L

April 16 – 279 mg/L

April 13 – 198 mg/L



**Settleable Solids (Imhoff Cone)**

12. Calculate the percent removal of settleable solids if the settleable solids of the sedimentation tank influent are 16.5 mL/L and the settleable solids of the effluent are 0.6 mL/L.
13. The settleable solids of the raw wastewater is 18 mL/L. If the settleable solids of the clarifier is 0.9 mL/L, what is the settleable solids removal efficiency of the clarifier?
14. The settleable solids of the raw wastewater is 20mL/L. If the settleable solids of the clarifier is 0.8 mL/L, what is the settleable solids removal efficiency of the clarifier?
15. Calculate the percent removal of settleable solids if the settleable solids of the sedimentation tank influent is 15 mL/L and the settleable solids of the effluent is 0.4 mL/L

**Settleability**

16. A settleability test is conducted on a sample of MLSS. What is the percent settleable solids if 440 mL settle in a 2000-mL graduated cylinder?

17. A 2000-mL sample of activated sludge is taken. If the settled sludge is measured as 320 mL, what is the percent settleable solids?
18. A settleability test is conducted on a sample of mixed liquor suspended solids. What is the percent settleable solids if 267 milliliters settle in the 2000 mL graduated cylinder?
19. A 2,000 milliliter sample of activated sludge is taken. If the settled sludge is measured as 488 mL, what is the percent settleable solids?
20. A 2000-mL sample of activated sludge is poured into a 2000-mL graduated cylinder. If the settled sludge is measured as 315 mL, what is the percent settleable solids?
21. The settleability test is conducted on a sample of MLSS. What is the percent settleable solids if 390 mL settle in the 2000-mL graduate?

**SVI and SDI**

22. After 30 minutes, a settleability test resulted in 220 mL of settleable solids in a 1-liter graduated cylinder. If the MLSS concentration in the aeration tank is 2210mg/L, what is the sludge volume index?
23. The settleability test indicates that after 30 minutes, there are 215 mL of suspended solids in the 1-liter graduate cylinder. If the MLSS concentration in the aeration tank is 2180 mg/L, what is the sludge volume index?
24. An activated sludge settleability test resulted in 410 mL settling in a 2-liter graduated cylinder. If the MLSS concentration in the aeration tank is 2310 mg/L, what is the sludge volume index?
25. The MLSS concentration in an aeration tank is 2110 mg/L. If the activated sludge settleability test indicates that 222 mL settled in a 1-liter graduated cylinder, what is the sludge density index?
26. Activated sludge in an aeration tank is found to have a concentration of MLSS of 2140 mg/L. If the settleability test results in 186 mL settleable solids in a 1-liter graduated cylinder after 30 minutes, what is the sludge density index?

27. After 30 minutes, a settleability test resulted in 215 mL of settleable solids in a 1-liter graduated cylinder. If the MLSS concentration in the aeration tank is 2510 mg/L, what is the sludge density index?

### **Total Solids and Volatile Solids**

28. Given the following information regarding a primary effluent sample, calculate (a) the percent total solids and (b) the percent volatile suspended solids of the sample.

|                           | Sludge<br>(Total Sample) | After Drying<br>(Before Burning) | After Burning<br>(Ash) |
|---------------------------|--------------------------|----------------------------------|------------------------|
| Weight of Sample & Dish   | 85.78 g                  | 26.27 g                          | 24.31 g                |
| Weight of Dish (Tare Wt.) | 21.50 g                  | 21.50 g                          | 21.50 g                |

29. Given the following information regarding a primary effluent sample, calculate (a) the percent total solids and (b) the percent volatile suspended solids of the sample.

|                           | Sludge<br>(Total Sample) | After Drying<br>(Before Burning) | After Burning<br>(Ash) |
|---------------------------|--------------------------|----------------------------------|------------------------|
| Weight of Sample & Dish   | 75.48 g                  | 22.67 g                          | 21.45 g                |
| Weight of Dish (Tare Wt.) | 20.80 g                  | 20.80 g                          | 20.80 g                |

30. Given the following information regarding a primary effluent sample, calculate (a) the percent total solids and (b) the percent volatile suspended solids of the sample.

|                           | Sludge<br>(Total Sample) | After Drying<br>(Before Burning) | After Burning<br>(Ash) |
|---------------------------|--------------------------|----------------------------------|------------------------|
| Weight of Sample & Dish   | 62.19 g                  | 28.31 g                          | 26.00 g                |
| Weight of Dish (Tare Wt.) | 19.96 g                  | 19.96 g                          | 19.96 g                |

**Suspended Solids and Volatile Suspended Solids**

31. Given the following information regarding a primary effluent sample, calculate (a) the mg/L suspended solids and (b) the percent volatile suspended solids of the sample.

| Sample Volume = 50 mL     | After Drying<br>(Before Burning) | After Burning<br>(Ash) |
|---------------------------|----------------------------------|------------------------|
| Weight of Sample & Dish   | 25.6818 g                        | 25.6802 g              |
| Weight of Dish (Tare Wt.) | 25.6715 g                        | 25.6715 g              |

32. Given the following information regarding a treatment plant influent sample, calculate (a) the mg/L suspended solids and (b) the percent volatile suspended solids of the sample.

| Sample Volume = 25 mL     | After Drying<br>(Before Burning) | After Burning<br>(Ash) |
|---------------------------|----------------------------------|------------------------|
| Weight of Sample & Dish   | 36.1588 g                        | 36.1543 g              |
| Weight of Dish (Tare Wt.) | 36.1496 g                        | 36.1496 g              |

33. Given the following information regarding a primary effluent sample, calculate (a) the mg/L suspended solids and (b) the percent volatile suspended solids of the sample.

| Sample Volume = 25 mL     | After Drying<br>(Before Burning) | After Burning<br>(Ash) |
|---------------------------|----------------------------------|------------------------|
| Weight of Sample & Dish   | 36.1544 g                        | 36.1500 g              |
| Weight of Dish (Tare Wt.) | 36.1477 g                        | 36.1477 g              |

34. Given the following information regarding a treatment plant influent sample, calculate (a) the mg/L suspended solids and (b) the percent volatile suspended solids of the sample.

| Sample Volume = 25 mL     | After Drying<br>(Before Burning) | After Burning<br>(Ash) |
|---------------------------|----------------------------------|------------------------|
| Weight of Sample & Dish   | 28.3196 g                        | 28.3082 g              |
| Weight of Dish (Tare Wt.) | 28.2981 g                        | 28.2981 g              |

**Alkalinity**

35. Alkalinity titration on a 100-mL sample resulted in 5.1 mL of 0.02N  $\text{H}_2\text{SO}_4$  to drop the pH from 7.8 to 4.5.
36. To drop the pH from 7.7 to 4.5 on a 100-mL sample 12.3 mL of 0.02N  $\text{H}_2\text{SO}_4$  was used to determine the alkalinity.
37. Calculate the total alkalinity in mg/L as  $\text{CaCO}_3$  for a sample of raw wastewater that required 10.1 mL of 0.02N  $\text{H}_2\text{SO}_4$  to titrate 100 mL sample from pH 7.5 to 4.5.
38. It took 31 mL of 0.02N  $\text{H}_2\text{SO}_4$  to drop the pH of a 100 mL wastewater sample from 8.24 to 4.5. What is the alkalinity in mg/L  $\text{CaCO}_3$ ?
39. Calculate the total alkalinity based on the following results:
- Sample size = 100 mL
  - mL of titrant used = 20 mL
  - Acid Normality = 0.02N  $\text{H}_2\text{SO}_4$



**Molarity**

40. If 2.9 moles of solute are dissolved in 0.8 liters solution, what is the molarity of the solution?

41. A 0.6 molar solution is to be prepared. If a total of 500 mL solution is to be prepared, how many moles solute will be required?

42. The atomic weight of calcium is 40. If 28 grams of calcium are used in making up a 1 liter solution, how many moles are used?

**Normality**

43. If 2.0 equivalents of a chemical are dissolved in 1.5 liters of solution, what is the normality of the solution?

44. An 800 mL solution contains 1.6 equivalents of a chemical. What is the normality of the solution?

45. The molecular weight of  $\text{Na}_2\text{CO}_3$  is 106. The net valence is 2. If 105 grams of  $\text{Na}_2\text{CO}_3$  are dissolved in a solution, how many equivalents are dissolved in the solution?

46. How many milliliters of 0.7N NaOH will react with 750 mL of 0.05N HCl?

**Solutions, Making Standards**

47. How many mL of 5N NaOH is required to make 1000 mL of 0.5N NaOH?

48. How many mL of 0.5 N NaOH react with 800 mL of 0.1 N HCl?

49. How many mL of 50 mg/L  $\text{PO}_4$  standard is needed to create 1000 mL of 3 mg/L  $\text{PO}_4$  solution?

50. You need to make 100 mL of 0.02N  $\text{H}_2\text{SO}_4$  in order to perform an alkalinity titration. The only  $\text{H}_2\text{SO}_4$  that you have in the lab is 6N. How many mL of 6N  $\text{H}_2\text{SO}_4$  will be required?
51. When conducting your ammonia QC at the end of the month, you need to run a lab fortified blank with a concentration of 5.0 mg/L. How many mL of 10 mg/L  $\text{NH}_3\text{-N}$  standard will be needed to create 100 mL for your lab fortified blank?
52. How many mL of 0.2N NaOH will react with 500 mL of 0.01N HCl?
53. A 2-liter volume of 0.05N HCl solution is to be prepared. How many mL of 9N HCl must be diluted with water to prepare the desired volume?
54. It takes 8.2 mL of a solution of HCl to neutralize 10 mL of 4N NaOH. What is the concentration of the HCl solution?

**Bacteriological, fecal coliform and *E. coli***

55. Determine the number of bacterial colonies (CFU)/100 mL for a 25 mL sample that had 50 colonies grow on the membrane filter for fecal coliforms.

56. An operator ran 3 dilutions on an *E. coli* sample. Calculate the number of colony forming units (CFU) per 100 mL of sample based on the results listed in the table.

|               | Filter # 1 | Filter # 2 | Filter # 3 |
|---------------|------------|------------|------------|
| Sample Volume | 100 mL     | 50 mL      | 10 mL      |
| Colony Count  | TNTC       | 79         | 11         |

57. Given the following mColi Blue results, calculate the number of bacterial colonies (CFU) per 100 mL of water.

| Filtration Volume | Colony Count |
|-------------------|--------------|
| 100 mL            | 119          |
| 75 mL             | 80           |
| 50 mL             | 65           |
| 25 mL             | 41           |
| 12 mL             | 2            |

58. Determine the bacteria colonies/100 mL when a membrane filtration test was performed for *E. coli*, after 24-hours of incubation, 57 colonies were counted. The sample volume used was 75 mL.
59. A total of 78 colonies grew after filtering a 10 mL sample. Calculate the number of colony forming units (CFU) per 100 mL.

### **Geometric Mean**

60. Determine the geometric mean for the following samples:

Sample #1 = 45.0 mg/L  
Sample #2 = 61.0 mg/L  
Sample #3 = 98.0 mg/L  
Sample #4 = 150.0 mg/L

61. Calculate the geometric mean for the following fecal coliform test results: 60, 100, 0, 0, 40, 20, 20, 45, 55, 60, 20, 20

62. Determine the geometric mean for the following samples:

Sample #1 = 20.0 mg/L  
Sample #2 = 20.0 mg/L  
Sample #3 = 210.0 mg/L  
Sample #4 = 3,500.0 mg/L

63. Calculate the geometric mean for the following E. coli test results: 22, 26, 64, 61, 54, 52, 67, 67, 79, 48

64. A lab is required to run 5 E. coli tests per week. Based on the monthly test results listed below, determine the geometric mean that will be reported to the state.

|        | Results, # of CFU/100 mL |
|--------|--------------------------|
| Week 1 | 25, 64, 75, 61, 57       |
| Week 2 | 0, 0, 15, 21, 11         |
| Week 3 | 79, 66, 48, 36, 32       |
| Week 4 | 22, 24, 0, 69, 78        |

### **Oxygen Uptake Rate (OUR)**

65. Dissolved air concentrations are taken on an air-saturated sample of digested aerobic sludge at one-minute intervals. Given the following results, calculate the oxygen uptake rate, mg/L/hr.

| Elapsed Time, min | DO, mg/L |
|-------------------|----------|
| 0                 | 8.2      |
| 1                 | 7.3      |
| 2                 | 6.7      |
| 3                 | 6.5      |
| 4                 | 6.3      |
| 5                 | 6.2      |

66. Dissolved air concentrations are taken on an air-saturated sample of digested aerobic sludge at one-minute intervals. Given the following results, calculate the oxygen uptake rate, mg/L/hr.

| Elapsed Time,<br>min | DO,<br>mg/L |
|----------------------|-------------|
| 0                    | 8.5         |
| 1                    | 7.8         |
| 2                    | 7.3         |
| 3                    | 6.7         |
| 4                    | 6.1         |
| 5                    | 5.3         |

**Specific Oxygen Uptake Rate (SOUR)**

67. Using the OUR result from #65 above, calculate the specific oxygen uptake rate (SOUR) if the MLVSS concentration is 2300 mg/L.

68. Using the OUR result from #66 above, calculate the specific oxygen uptake rate (SOUR) if the MLVSS concentration is 1950 mg/L .

**Answers:**

1. 177.32 mL
2. 114.71 mL
3. 21.13 degrees C
4. 75.2 degrees F
5. 25.02 degrees C
6. 15.57 degrees C
7. 75.2 degrees F
8. 60.8 degrees F
9. 184.29 mg/L
10. 83 mg/L
11. 234.86 mg/L
12. 96.36%
13. 95%
14. 96%
15. 97.34%
16. 22%
17. 16%
18. 13.35%
19. 24.4%
20. 15.75%
21. 19.5%
22. 99.55 mL/g
23. 98.62 mL/g
24. 88.74 mL/g
25. SVI=105.21 mL/g, SDI=0.95
26. SVI=86.92 mL/g, SDI=1.15
27. SVI=85.66 mL/g, SDI=1.17
28. a) 7.42% b) 41%
29. a) 3.42% b) 65.24%
30. a) 19.77% b) 27.66%
31. a) 206 mg/L b) 15.53%
32. a) 368 mg/L b) 48.91%
33. a) 268 mg/L b) 70.13%
34. a) 860 mg/L b) 53.02%
35. 51 mg/L as CaCO<sub>3</sub>
36. 123 mg/L as CaCO<sub>3</sub>
37. 101 mg/L as CaCO<sub>3</sub>
38. 310 mg/L as CaCO<sub>3</sub>
39. 200 mg/L as CaCO<sub>3</sub>
40. 3.625 M
41. 0.3 moles
42. 0.7 moles
43. 1.3334 N
44. 2 N
45. 1.98 equivalent weights
46. 53.57 mL NaOH
47. 100 mL
48. 160 mL
49. 60 mL
50. 0.3334 mL
51. 50 mL
52. 25 mL
53. 11.11 mL
54. 4.88 N
55. 200 cfu/100 mL
56. 158 cfu/100 mL
57. 133.56 cfu/100 mL
58. 76 cfu/100 mL
59. 780 cfu/100 mL
60. 79.70
61. 20.61
62. 130.94
63. 50.45
64. 22.58
65. 10 mg/L/hr
66. 40 mg/L/hr
67. 4.35 mg O<sub>2</sub>/hr/gm
68. 20.51 mg O<sub>2</sub>/hr/gm



## **Section 11**

### **Activated Sludge**

Applied Math for Wastewater Systems

## **ACTIVATED SLUDGE**

### Activated Sludge

- ⦿ Biological treatment systems that use a suspended growth of microorganisms to remove BOD and SS.
- ⦿ Basic components: aeration basin and secondary clarifier
- ⦿ Must periodically waste some sludge (WAS)
- ⦿ Microorganisms that settle out in the secondary clarifier are returned to the aeration basin (RAS)

## Activated Sludge

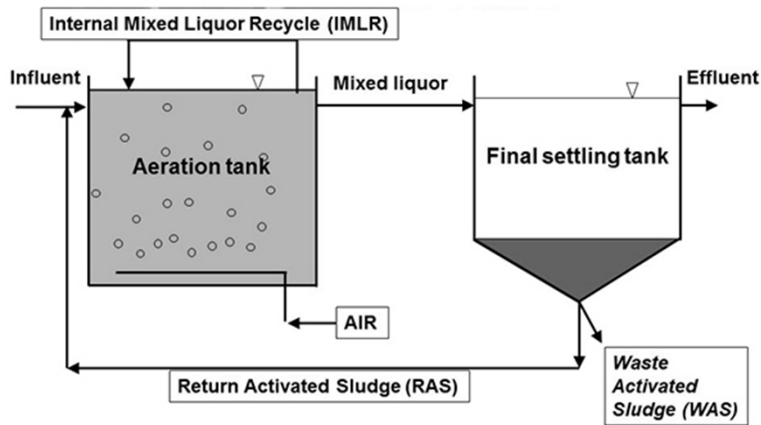

## Activated Sludge

- BOD, COD, or SS Loading
- Solids Inventory in the Aeration Tank
- Food:Microorganism Ratio (F:M)
- Mean Cell Residence Time (MCRT), aka Solids Retention Time (SRT)
- Return Sludge Rate
- Wasting Rate
- WAS Pumping Rate
- Oxidation Ditch Detention Time

## BOD, COD, or SS Loading

- ◎ *Pounds Formula!*

$(\text{Concentration, mg/L})(\text{Flow, MGD})(8.34 \text{ lbs/gal}) = \text{lbs/day}$

- Note: If you plug in the correct units, you do not have to worry about canceling out units, the formula is constructed to do it for you.

- ◎ Note: In the ABC Formula book, this formula is called **“Loading Rate, lb/day”**

## BOD, COD, or SS Loading

- ◎ *Example 1:* The BOD concentration of the wastewater entering an aerator is 215 mg/L. If the flow to the aerator is 1,440,000 gpd, what is the lbs/day of BOD loading?

- ◎  $(\text{Concentration, mg/L})(\text{Flow, MGD})(8.34 \text{ lbs/gal}) = \text{lbs/day}$
- ◎  $(215 \text{ mg/L})(1.44 \text{ MGD})(8.34) = 2582 \text{ lbs/day}$

## Solids Inventory in the Aeration Tank

- ⦿ It is important to control the amount of solids under aeration.
- ⦿ The suspended solids in an aeration tank are called Mixed Liquor Suspended Solids (MLSS)
- ⦿ Another important measure is the Mixed Liquor Volatile Suspended Solids (MLVSS)
  - This is an estimate of the microorganism population in the aeration tank
- ⦿ MLVSS is usually about 70% of the MLSS
  - The remaining 30% is fixed (inorganic) solids
- ⦿ Again, *Pounds Formula!*

## Solids Inventory in the Aeration Tank

- ⦿ Note: In the ABC Formula book, this formula is called “**Mass, lb**”
  
- ⦿ Example 1: If the MLSS concentration is 1100 mg/L, and the aeration tank has a volume of 525,000 gallons, how many pounds of suspended solids are in the aeration tank?
- ⦿ (Concentration, mg/L)(Volume, MG)(8.34 lb/gal) = Mass, lbs
- ⦿ (1100 mg/L)(0.525 MG)(8.34) = 4816 lbs MLSS

## F:M Ratio

- ⦿ In order for the activated sludge process to work properly, there must be a balance between the Food entering the system (BOD or COD) and microorganisms in the aeration tank (MLVSS).
- ⦿ COD can be used if there is an established correlation between BOD and COD
  - COD test results in 2 hours (versus 5 days for BOD)
- ⦿ Usually, BOD, COD, and MLVSS data will be given as mg/L and must be converted to lbs
  - Use the expanded formula to do this.

## F:M Ratio

⦿ 
$$\text{F:M Ratio} = \frac{\text{BOD, lbs/day}}{\text{MLVSS, lb}}$$

Expanded formula:

⦿ 
$$\text{F:M Ratio} = \frac{(\text{BOD, mg/L})(\text{Flow, MGD})(8.34 \text{ lbs/gal})}{(\text{MLVSS, mg/L})(\text{Aer Vol, MG})(8.34 \text{ lbs/gal})}$$

- ⦿ Note: The expanded formula is not included in the ABC formula book.

## F:M Ratio

- *Example 1:* An activated sludge aeration tank receives a primary effluent flow of 2.42 MGD with a BOD of 170 mg/L. The MLVSS is 1980 mg/L and the aeration tank volume is 350,000 gallons. What is the current F:M ratio?

- $$\text{F:M Ratio} = \frac{(\text{BOD, mg/L})(\text{Flow, MGD})(8.34 \text{ lbs/gal})}{(\text{MLVSS, mg/L})(\text{Aer Vol, MG})(8.34 \text{ lbs/gal})}$$

- $$\text{F:M Ratio} = \frac{(170, \text{mg/L})(2.42 \text{ MGD})(8.34 \text{ lbs/gal})}{(1980 \text{ mg/L})(0.35 \text{ MG})(8.34 \text{ lbs/gal})}$$

- $$\text{F:M Ratio} = 0.59$$

## Mean Cell Residence Time

- Also called Solids Retention Time (SRT)
- Represents the average length of time an activated biosolids particle stays in the activated biosolids system.
- MCRT/SRT is based on suspended solids leaving the system
- When calculating the lbs MLSS, both the aeration tank and final clarifier volumes are normally used.
- Basically 4 *Pounds Formulas*

## Mean Cell Residence Time

⊙  $MCRT, \text{ days} = \frac{\text{Suspended Solids in System, lbs}}{\text{Suspended Solids Leaving System, lbs/day}}$

⊙  $MCRT, \text{ days} = \frac{\text{Suspended Solids in System, lbs}}{\text{WAS SS, lbs/day} + \text{S.E. SS, lbs/day}}$

- WAS = suspended solids conc of WAS
  - S.E. SS = suspended solids conc in secondary clarifier effluent
- ← Intentional Wasting
- ← Unintentional Wasting

## Mean Cell Residence Time

⊙ In ABC Formula Book:

$MCRT \text{ or } SRT, \text{ days} = \frac{(\text{Aeration Tank TSS, lb}) + (\text{Clarifier TSS, lb})}{(\text{TSS Wasted, lb/day}) + (\text{Effluent TSS, lb/day})}$

Solids in the System

MCRT, days =

$$\frac{\left(MLSS, \frac{\text{mg}}{\text{L}}\right)(\text{Aer. Vol, MG})\left(8.34 \frac{\text{lbs}}{\text{gal}}\right) + \left(CCSS, \frac{\text{mg}}{\text{L}}\right)(\text{Fin. Clar. Vol, MG})\left(8.34 \frac{\text{lbs}}{\text{gal}}\right)}{\left(\text{WAS SS, } \frac{\text{mg}}{\text{L}}\right)(\text{WAS, MGD})\left(8.34 \frac{\text{lbs}}{\text{gal}}\right) + \left(\text{S.E. SS, } \frac{\text{mg}}{\text{L}}\right)(\text{Plant Flow, MGD})\left(8.34 \frac{\text{lbs}}{\text{gal}}\right)}$$

Solids Leaving the System

Note: CCSS = Average Clarifier Core SS Concentration



## Mean Cell Residence Time

◎ *Example 1:* Determine the MCRT given the following data.

- Aer. Vol. = 1.5 MG
- Fin. Clar. Vol. = 0.11 MG
- P.E. Flow = 3.4 MG
- WAS Pumping Rate = 60,000 gpd
- MLSS = 2460 mg/L
- WAS SS = 8040 mg/L
- S.E. SS = 18 mg/L
- CCSS = 1850 mg/L

$$\text{MCRT} = \frac{\left(\text{MLSS}, \frac{\text{mg}}{\text{L}}\right)(\text{Aer. Vol, MG})\left(8.34 \frac{\text{lbs}}{\text{gal}}\right) + \left(\text{CCSS}, \frac{\text{mg}}{\text{L}}\right)(\text{Fin. Clar. Vol, MG})\left(8.34 \frac{\text{lbs}}{\text{gal}}\right)}{\left(\text{WAS SS}, \frac{\text{mg}}{\text{L}}\right)(\text{WAS, MGD})\left(8.34 \frac{\text{lbs}}{\text{gal}}\right) + \left(\text{S.E. SS}, \frac{\text{mg}}{\text{L}}\right)(\text{Plant Flow, MGD})\left(8.34 \frac{\text{lbs}}{\text{gal}}\right)}$$

$$\text{MCRT} = \frac{(2460 \text{ mg/L})(1.5 \text{ MG})\left(8.34 \frac{\text{lbs}}{\text{gal}}\right) + (1850 \text{ mg/L})(0.11 \text{ MG})\left(8.34 \frac{\text{lbs}}{\text{gal}}\right)}{(8040 \text{ mg/L})(.06 \text{ MGD})\left(8.34 \frac{\text{lbs}}{\text{gal}}\right) + (18 \text{ mg/L})(3.4 \text{ MGD})\left(8.34 \frac{\text{lbs}}{\text{gal}}\right)}$$

$$\text{MCRT} = \frac{30,775 \text{ lbs MLSS} + 1697 \text{ lbs CCSS}}{4023 \text{ lbs/day SS} + 510 \text{ lbs/day SS}}$$

$$\text{MCRT} = 7.2 \text{ days}$$

## Mean Cell Residence Time

◎ *Example 2:* An aeration tank has a volume of 425,000 gal. The final clarifier has a volume of 120,000 gal. The MLSS concentration of the aerator is 2780 mg/L. If a total of 1640 lbs/day SS are wasted and 340 lbs/day SS are in the secondary effluent, what is the MCRT?

$$\text{MCRT, days} = \frac{\text{Suspended Solids in System, lbs}}{\text{WAS SS, lbs/day} + \text{S.E. SS, lbs/day}}$$

$$\text{MCRT, days} = \frac{(2780 \text{ mg/L})(0.545 \text{ MGD})(8.34)}{1640 \text{ lbs/day} + 340 \text{ lbs/day}}$$

$$\text{MCRT, days} = \frac{12,636 \text{ lbs MLSS}}{1980 \text{ lbs/day SS leaving}}$$

$$\text{MCRT} = 6.4 \text{ days}$$

## Return Sludge Rate

- ⦿ A key aspect in the proper operation of an activated sludge system is maintaining a balance between the food entering the system (BOD or COD) and the microorganisms in the system.
- ⦿ Since there is not much control in the amount of food entering, most of the control is focused on maintaining an adequate solids inventory.
- ⦿ RAS flow rate

## Return Sludge Rate

- ⦿ Simplified Equation:  
Suspended Solids In = Suspended Solids Out
- ⦿ Expanded Equation:

$$\begin{array}{ccc} \text{Suspended Solids In, lbs/day} & & \text{Suspended Solids Out, lbs/day} \\ \left[ (\text{RAS SS})(R) \right] & = & \left[ (\text{MLSS})(Q + R) \right] \\ \swarrow & & \nwarrow \\ \text{Solids entering aeration tank} & & \text{Solids Leaving aeration tank} \end{array}$$

Where:

- R = Return Sludge Flow, MGD
- Q = Secondary Influent flow, MGD

## Return Sludge Rate

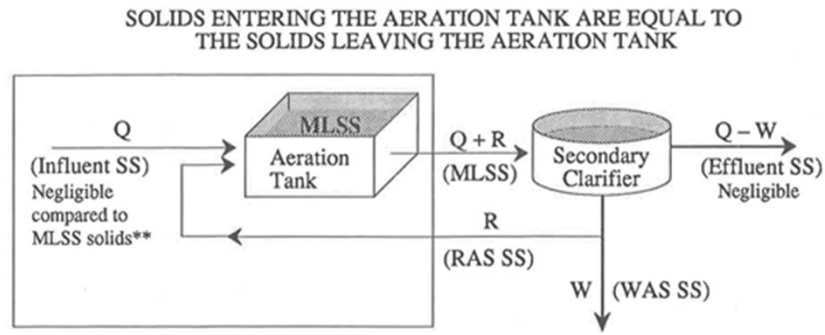

◎ Remember:  $Q = \text{Flow}$

## Return Sludge Rate

◎ Equation can be rearranged to solved for R...

◎ In ABC Formula book:

$$\text{Return Sludge Rate - Solids Balance} = \frac{(\text{MLSS, mg/L})(\text{Flow Rate, MGD})}{(\text{RAS Suspended Solids}) - (\text{MLSS, mg/L})}$$

- The name comes from Return Sludge Rate using Aeration Tank Solids Balance

◎ In FTC Formula book:

$$\text{Return Sludge Flow, gal/day} = \frac{(\text{Aer. Influent Flow, gal/day})(\text{MLSS, mg/L})}{\text{Return Sludge Conc, mg/L} - \text{MLSS, mg/L}}$$

## Return Sludge Rate

- ◎ *Example 1:* Given the following data, calculate the RAS return rate.
  - MLSS = 2100 mg/L
  - RAS SS = 7490 mg/L
  - Q = 6.3 MGD
- ◎ Return Sludge Rate –Solids Balance =  $\frac{(\text{MLSS,mg/L})(\text{Flow Rate,MGD})}{(\text{RAS Suspended Solids})-(\text{MLSS,mg/L})}$
- ◎ Return Sludge Rate –Solids Balance =  $\frac{(2100 \text{ mg/L})(6.3 \text{ MGD})}{(7490 \text{ mg/L})-(2100 \text{ mg/L})}$
- ◎ Return Sludge Rate = 2.45 MGD

## Wasting Rate

- ◎ It is critical to maintain a proper balance between the food entering the system and the microorganisms in the system.
- ◎ The size of the microorganism population naturally increases as food is consumed (measured by BOD or COD removed).
- ◎ Therefore, to maintain the same F:M ratio, a portion of the microorganisms must be removed (or wasted) periodically.

## Wasting Rate

- There are several ways to determine WAS rate
- F:M Ratio
- SRT (MCRT)

COMPARE DESIRED MLSS WITH ACTUAL MLSS TO DETERMINE EXCESS MLSS

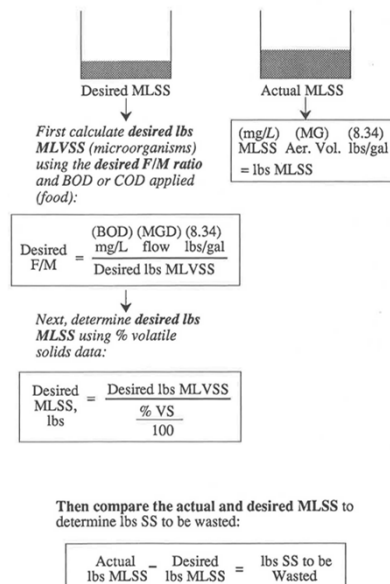

From Applied Math for Wastewater Operators by Joanne Kirkpatrick Price

## Wasting Rate

- Using the F:M Ratio
- Example:** The desired F:M Ratio is 0.3 lbs BOD/lb MLVSS. It has been calculated that 5900 lbs/day BOD enter the aeration tank. The MLVSS content is 70%. Based on the desired F:M Ratio, what is the desired lbs MLSS?
- $$\frac{0.3 \text{ lbs/day BOD}}{1 \text{ lb MLVSS}} = \frac{5900 \text{ lbs/day BOD}}{x \text{ lbs MLVSS}}$$
- $$X = \frac{5900}{0.3} = 19,667 \text{ lbs MLVSS desired}$$
- Then calculate the desired lbs. MLSS, using % VS content:
- $$\frac{19,667 \text{ lbs MLVSS}}{0.70 \text{ VS content}} = 28,096 \text{ lbs MLSS desired}$$
- You could then compare the actual and desired MLSS to determine lbs SS to be wasted.

## Wasting Rate

- Using the SRT equation
- Since wasting rate is part of the SRT equation, make it your unknown variable

USE THE SRT EQUATION TO DETERMINE  
WASTING RATE

Simplified Equation:

$$\text{Solids Retention Time} = \frac{\text{Suspended Solids in System lbs}}{\text{WAS SS, lbs/day} + \text{S.E. SS, lbs/day}}$$

↑  
lbs/day SS  
to be Wasted

Expanded Equation:

$$\text{SRT} = \frac{(\text{MLSS mg/L})(\text{Aer.} + \text{Fin. Clar. Vols., MG})(8.34 \text{ lbs/gal})}{\text{WAS SS, lbs/day} + (\text{S.E. SS})(\text{MGD})(8.34)}$$

↑  
lbs/day SS  
to be Wasted

## Wasting Rate

- Example:* The desired MCRT for an activated sludge plant is 8.5 days. The secondary effluent flow has 690 lbs/day SS. There is a total of 30,000 lbs SS in the system. How many lbs/day WAS SS must be wasted to maintain the desired MCRT?

$$\text{MCRT} = \frac{(\text{MLSS, } \frac{\text{mg}}{\text{L}})(\text{Aer. Vol, MG})(8.34 \frac{\text{lbs}}{\text{gal}}) + (\text{CCSS, } \frac{\text{mg}}{\text{L}})(\text{Fin. Clar. Vol, MG})(8.34 \frac{\text{lbs}}{\text{gal}})}{(\text{WAS SS, } \frac{\text{mg}}{\text{L}})(\text{WAS, MGD})(8.34 \frac{\text{lbs}}{\text{gal}}) + (\text{S.E. SS, } \frac{\text{mg}}{\text{L}})(\text{Plant Flow, MGD})(8.34 \frac{\text{lbs}}{\text{gal}})}$$

↙  
This becomes your unknown, then solve for x

- Also remember: everything in the numerator is equal to the amount of solids in the system.

## Wasting Rate

- $$\text{MCRT} = \frac{\text{Suspended Solids in the System, lbs}}{x \text{ lbs/day WAS SS} + \text{S.E.SS, lbs/day}}$$
- $$8.5 \text{ days} = \frac{30,000 \text{ lbs in System}}{x \text{ lbs/day WAS SS} + 690 \text{ lbs/day}}$$
- $$\frac{(x \text{ WAS} + 690) \cdot 8.5 \text{ days}}{1} = \frac{30,000 \text{ lbs in System}}{x \text{ lbs/day WAS SS} + 690 \text{ lbs/day}} \cdot \frac{(x \text{ WAS} + 690)}{1}$$
- $$\frac{(x \text{ WAS} + 690)(8.5 \text{ days})}{8.5 \text{ days}} = \frac{30,000 \text{ lbs in System}}{8.5 \text{ days}}$$
- $$x \text{ WAS} + 690 = 3529$$
- $$x \text{ WAS} = 3529 - 690$$

← Subtract 690 from both sides of the equation.
- $$x = 2839 \text{ lbs/day WAS SS}$$

Any Questions?



## Reference:

- **Applied Math for Wastewater Plant Operators** by Joanne Kirkpatrick Price  
Technomic Publishing Company, Inc  
1991



## Activated Sludge Notes

### BOD or COD Loading, lbs/day

- This is the food part of the F/M ratio
- COD is sometimes used if there is a good correlation between it and BOD
- Loading guidelines for the 3 operational modes of Activated Sludge are:
  - High Rate
    - COD: greater than 1 lb COD/day/lb MLVSS under aeration
    - BOD: greater than 0.5 lb BOD/day/lb MLVSS under aeration
  - Conventional
    - COD: 0.5 to 1 lb COD/day/lb MLVSS under aeration
    - BOD: 0.25 to 0.5 lb BOD/day/lb MLVSS under aeration
  - Extended Aeration
    - COD: less than 0.2 lb COD/day/lb MLVSS under aeration
    - BOD: less than 0.1 lb BOD/day/lb MLVSS under aeration
- For untreated domestic wastewater,  $BOD = (0.4 \text{ to } 0.8)(COD)$

### Solids Inventory in the Aeration Tank, lbs. MLSS or lbs. MLVSS

- In an activated sludge system, the solids under aeration must be controlled
- The SS in aeration tank are the MLSS
- MLVSS is an estimate of the microorganism population in the aeration tank.
- The MLVSS is typically 70% of the MLSS, the remaining 30% are fixed (or inorganic) solids

### Food to Microorganism Ratio

- In order for an Activated Sludge system to operate properly, there must be a balance between the food (BOD or COD) and bugs in the aeration tank (MLVSS).
- The F/M ratio is a process control calculation used in many activated sludge plants
- Best F/M depends on the type of activated sludge system and the wastewater characteristics
- The F/M ratio is calculated from the amount of BOD or COD applied each day and from the solids inventory in the aeration tank.
- Typical ranges for F/M (using BOD):
  - Conventional ranges are 0.2-0.4
  - Extended Aeration ranges are 0.05-0.15

### **Mean Cell Residence Time (MCRT), days**

- Also called SRT, Solids Retention Time
- Approach used for solids control, adjust WAS to maintain MCRT
- Most desirable MCRT for a plant is determined experimentally
- Typical ranges are:
  - Conventional plants MCRT is 5-15 days
  - Extended aeration MCRT is 20-30 days
- MCRT based on suspended solids leaving the system and includes the aeration tank and final clarifier
- Also can determine the type of bugs that predominate and therefore the degree of nitrification that may occur
  - From AWT Table 2.6: MCRT needed to produce nitrified effluent as related to temp
    - 10°C – 30 days
    - 15°C – 20 days
    - 20°C – 15 days
    - 25°C – 10 days
    - 30°C – 7 days

### **Wasting Rates**

- The amount of activated sludge wasted may vary from 1-20% of total incoming flow
- Expressed in lbs or gallons/day
- Wasting is the diverting of flow to primary clarifier, thickener, gravity belt thickener or aerobic or anaerobic digester

## Applied Math for Wastewater Treatment Activated Sludge

### BOD or COD Loading, lbs/day

1. The flow to an aeration tank is 850,000 gpd. If the BOD content of the wastewater entering the aeration tank is 225 mg/L, how many pounds of BOD are applied to the aeration tank daily?

### Solids Inventory in the Aeration Tank, lbs. MLSS or lbs. MLVSS

2. An aeration basin is 120 ft long, 45 ft wide and holds wastewater to a depth of 12 ft. If the aeration basin has an MLSS concentration of 2150 mg/L, how many pounds of MLSS are under aeration?
  
3. The aeration tank of a conventional activated sludge plant has an MLSS concentration of 2300 mg/L with a volatile solids content of 72%. If the volume of the aeration tank is 200,000 gallons, how many pounds of volatile solids are under aeration?

**Food to Microorganism Ratio**

4. An activated sludge aeration tank receives a primary effluent flow of 1.6 MGD with a BOD concentration of 180 mg/L. The mixed liquor volatile suspended solids is 2200 mg/L and the aeration tank volume is 420,000 gallons. What is the current F/M ratio?
  
5. The flow to a 195,000 gallon oxidation ditch is 365,000 gpd. The BOD concentration of the wastewater is 170 mg/L. If the MLSS concentration is 2550 mg/L with a volatile content of 70%, what is the F/M ratio?
  
6. The desired F/M ratio of an extended aeration activated sludge plant is 0.5 lbs COD/lb. MLVSS. If the 3.0 MGD primary effluent flow has a COD of 172 mg/L, how many lbs of MLVSS should be maintained in the aeration tank?

**Mean Cell Residence Time (MCRT), days [also called Solids Retention time (SRT)]**

7. An activated sludge system has a total of 28,500 lbs of mixed liquor suspended solids. The suspended solids leaving the final clarifier in the effluent is 400 lbs/day. The pounds suspended solids wasted from the final clarifier is 2910 lbs/day. What is the solids retention time (MCRT), days?

8. Determine MCRT given the following information:

Aeration Tank = 1,400,000 gal  
Final Clarifier = 105,000 gal  
Flow = 3,000,000 gpd  
WAS Pump Rate = 68,000 gpd

MLSS = 2650 mg/L  
S.E. SS = 22 mg/L  
CCSS = 1890 mg/L  
WAS = 6050 mg/L

**Return Sludge Rate**

9. Given the following data, calculate the RAS return rate (using the aeration tank solids balance equation).

MLSS = 3300 mg/L

RAS SS = 4750 mg/L

Q = 6.7 MGD

**Wasting Rates**

10. Using Constant F/M Ratio: The desired F/M ratio for an activated sludge system is 0.6 lbs BOD/lb MLVSS. It has been calculated that 3300 lbs of BOD enter the aeration basin daily. If the volatile solids content of the MLSS is 68%, how many lbs MLSS are desired in the aeration basin?

11. Using Constant MCRT: The desired MCRT for an activated sludge plant is 8.5 days. The secondary effluent flow is 3.16 MGD with a suspended solids content of 22 mg/L. There is a total of 32,100 lbs SS in the system. How many lbs/day WAS SS must be wasted to maintain the desired MCRT?

**Answers:**

1. 1595.03 lbs/day
2. 8691.23 lbs
3. 2762.21 lbs
4. 0.31
5. 0.18
6. 8606.88 lbs MLVSS/day
7. 8.61 days
8. 8.19 days
9. 15.25 MGD
10. 8088.24 lbs
11. 3196.67 lbs/day

**Applied Math for Wastewater Treatment  
Activated Sludge - Additional Problems**

**BOD or COD Loading, lbs/day**

1. The flow to an aeration basin is 880,000 gpd. If the BOD content of the wastewater entering the aeration basin is 240 mg/L, what is the lbs/day BOD loading?
  
  
  
  
  
  
  
  
  
  
2. The flow to the aeration basin is 2980 gpm. If the COD concentration of the wastewater is 160 mg/L, how many lbs of COD are applied to the aeration basin daily?
  
  
  
  
  
  
  
  
  
  
3. The BOD content of the wastewater entering an aeration basin is 165 mg/L. If the flow to the aeration basin is 3,240,000 gpd, what is the lbs/day BOD loading?
  
  
  
  
  
  
  
  
  
  
4. The daily flow to an aeration basin is 4,880,000 gpd. If the COD concentration of the influent wastewater is 150 mg/L, how many lbs of COD are applied to the aeration basin daily?



5. The flow to an aeration tank is 1200 gpm. If the COD concentration of the wastewater is 155 mg/L, what is the COD loading rate in lbs/day?
  
  
  
  
  
  
  
  
  
  
6. The flow to an aeration tank is 2875 gpm. If the BOD concentration of the wastewater is 125 mg/L, how many pounds of BOD are applied to the aeration tank daily?
  
  
  
  
  
  
  
  
  
  
7. The flow to an aeration tank is 9990 gpm. If the COD concentration of the wastewater is 120 mg/L, how many pounds of COD are applied to the aeration tank daily?

**Solids Inventory in the Aeration Basin, lbs. MLSS or lbs. MLVSS**

8. If the mixed liquor suspended solids concentration is 2110 mg/L and the aeration basin has a volume of 460,000 gallons, how many lbs of suspended solids are in the aeration basin?

9. The aeration basin of a conventional activated sludge plant has a mixed liquor volatile suspended solids (MLVSS) concentration of 2420 mg/L. If the aeration basin is 90 ft long by 50 ft wide and has wastewater to a depth of 16 ft, how many lbs of MLVSS are under aeration?
10. The aeration basin of a conventional activated sludge plant has a mixed liquor volatile suspended solids (MLVSS) concentration of 2410 mg/L. If the aeration basin is 80 ft long by 40 ft wide and has wastewater to a depth of 16 ft, how many lbs of MLVSS are under aeration?
11. An aeration basin is 110 ft long, 30 ft wide and has wastewater to a depth of 16 ft. If the aeration basin of this conventional activated sludge plant has a mixed liquor suspended solids (MLSS) concentration of 2740 mg/L, how many lbs of MLSS are under aeration?
12. An aeration basin is 110 ft long, 50 ft wide and has wastewater to a depth of 16 ft. If the mixed liquor suspended solids (MLSS) concentration in the aeration basin is 2470 mg/L with a volatile solids content of 73%, how many lbs of MLVSS are under aeration?

13. The volume of an aeration tank is 175,000 gallons. If the MLVSS concentration is 3220 mg/L, how many pounds of volatile solids are under aeration?
14. The aeration tank of a conventional activated sludge plant has a mixed liquor volatile suspended solids concentration of 2050 mg/L. The aeration tank is 85 feet long, 35 feet wide, and has wastewater to a depth of 15 feet. How many pounds of MLVSS are under aeration?

### **Food to Microorganism Ratio**

15. An activated sludge aeration basin receives a primary effluent flow of 2.75 MGD with a BOD concentration of 200 mg/L. The mixed liquor volatile suspended solids (MLVSS) concentration is 2610 mg/L and the aeration basin volume is 490,000 gallons. What is the current F/M ratio?
16. An activated sludge aeration basin receives a primary effluent flow of 3,390,000 gpd with a BOD of 171 mg/L. The mixed liquor volatile suspended solids (MLVSS) concentration is 2510 mg/L and the aeration basin volume is 590,000 gallons. What is the F/M ratio?

17. The flow to a 195,000 gallon oxidation ditch is 320,000 gpd. The BOD concentration of the wastewater is 180 mg/L. If the mixed liquor suspended solids (MLSS) concentration is 2540 mg/L with a volatile solids content of 72%, what is the F/M ratio?
18. The desired F/M ratio at an extended aeration activated sludge plant is 0.7 lb BOD/lb MLVSS. If the primary effluent flow is 3.3 MGD and has a BOD of 181 mg/L, how many pounds of MLVSS should be maintained in the aeration basin?
19. The desired F/M ratio at a particular activated sludge plant is 0.4 lbs BOD/lb MLVSS. If the primary effluent flow is 2,510,000 gpd and has a BOD concentration of 141 mg/L, how many lbs of MLVSS should be maintained in the aeration basin?
20. What is the F:M ratio for an aeration tank with a volume of 419,500 gallons, if the primary effluent flow is 5.77 MGD, the mixed liquor volatile suspended solids is 3,095 mg/L, and the BOD is 238 mg/L?

21. Determine the F/M ratio for an activated sludge plant with a primary effluent COD of 100 mg/L applied to the aeration tank, an influent flow of 7.5 MGD, and 33,075 lbs of solids under aeration. Seventy percent of the MLSS are volatile matter. All known values are seven-day moving averages.

**Mean Cell Residence Time (MCRT), days [also called Solids Retention Time (SRT)]**

22. An activated sludge system has a total of 29,100 lbs of MLSS. The concentration of suspended solids leaving the final clarifier in the effluent is calculated to be 400 lbs/day. Suspended solids wasted from the clarifier are 2920 lbs/day. What is the MCRT in days?

23. Determine the MCRT given the following data: aeration basin volume, 1,500,000 gallons; mixed liquor suspended solids, 2710 mg/L; final clarifier, 106,000 gallons; waste activated sludge, 5870 mg/L; WAS pumping rate, 72,000 gpd; plant flow, 3.3 MGD; secondary effluent SS, 25 mg/L; average clarifier core SS, 1940 mg/L.
24. An aeration basin has a volume of 460,000 gallons. The final clarifier has a volume of 178,000 gallons. The MLSS concentration in the aeration basin is 2222 mg/L. If 1610 lbs/day suspended solids are wasted and 240 lbs/day suspended solids are in the secondary effluent, what is the MCRT for the activated sludge system?

25. Determine MCRT given the following information:

Aeration Basin = 350,000 gal  
Final Clarifier = 125,000 gal  
Flow = 1,400,000 gpd  
WAS Pump Rate = 27,000 gpd

MLSS = 2910 mg/L  
S.E. SS = 16 mg/L  
WAS = 6210 mg/L

26. Given the following data, calculate the MCRT for this activated sludge system.

Aeration tanks and final clarifier volume = 0.677 MG  
MLSS = 3,580 mg/L  
Suspended solids wasted = 1,910 lb/day  
Secondary effluent suspended solids = 368 lb/day

27. Determine the MCRT given the following information:

Influent Flow,  $Q = 3$  MGD

Waste Sludge Flow = 0.040 MGD

Volume of aeration basin = 1.0 MG

MLSS = 1,600 mg/L

Effluent Suspended Solids = 8 mg/L

Waste Sludge Suspended Solids = 4,700 mg/L

### **Return Sludge Rate**

28. Given the following data, calculate the RAS return rate (using the aeration tank solids balance equation).

MLSS = 2100 mg/L

RAS SS = 7490 mg/L

$Q = 6.3$  MGD



29. Given the following data, calculate the RAS return rate using the aeration tank solids balance equation.
- MLSS = 3660 mg/L  
RAS SS = 6767 mg/L  
Flow = 6.4 MGD

### **Wasting Rates**

30. Using Constant F/M Ratio: The desired F/M ratio for an activated sludge system is 0.5 lbs BOD/lb MLVSS. It has been calculated that 3400 lbs of BOD enter the aeration basin daily. If the volatile solids content of the MLSS is 69%, how many lbs MLSS are desired in the aeration basin?

31. Given the following data, use the desired F/M ratio to determine the lbs SS to be wasted:

Aeration volume = 1,300,000 gal

Influent flow = 3,190,000 gpd

COD = 115 mg/L

Desired F/M ratio = 0.15 lbs COD/day/lb MLVSS

MLSS = 2980 mg/L

% VS = 70%

32. Using Constant MCRT: The desired MCRT for an activated sludge plant is 9 days. The secondary effluent flow is 3,220,000 gpd with a suspended solids content of 23 mg/L. There is a total of 32,400 lbs SS in the system. How many lbs/day WAS SS must be wasted to maintain the desired MCRT?

33. Given the following data, calculate the lbs/day WAS SS to be wasted/

Desired SRT = 9 days

Clarifier + Aerator Volume = 1.2 MG

MLSS = 3150 mg/L

S.E. SS = 16 mg/L

Influent flow = 6.9 MGD

34. Given the following data, determine the lbs/day suspended solids to be wasted:

Aeration Tank Volume = 1.2 MG

Influent Flow = 3,100,000 gpd

BOD = 110 mg/L

Desired F/M = 0.4

MLSS = 2200 mg/L

%VS = 68%

**Answers:**

1. 1761.41 lb/day
2. 5726.18 lb/day
3. 4458.56 lb/day
4. 6104.88 lb/day
5. 2233.79 lb/day
6. 4315.95 lb/day
7. 14,397.11 lb/day
8. 8094.80 lb
9. 10,869.65 lb
10. 7697.59 lb
11. 9025.10 lb
12. 9898.52 lb
13. 4699.59 lb
14. 5706.89 lb
15. 0.43
16. 0.39
17. 0.16
18. 7116.40 lb
19. 7379.02 lb
20. 1.06
21. 0.27
22. 8.77 days
23. 8.45 days
24. 6.39 days
25. 7.27 days
26. 8.87 days
27. 7.55 days
28. 2.45 MGD
29. 7.54 MGD
30. 9855.07 lbs
31. 3170.79 lbs
32. 2982.34 lb/day
33. 2582.06 lb/day
34. 11561.92 lb

## **Section 12**

# **Sludge Digestion**

Applied Math for Wastewater Treatment Systems

# SLUDGE PRODUCTION, THICKENING, AND DIGESTION

## Solids

- ◎ You need to know how to calculate solids produced
  - These are the solids that settle in, or are removed by, the clarifier
  - POUNDS FORMULA
- ◎ How much solids are being sent to digester
  - Want to avoid overloading, underloading, upsetting the Volatile Acid/Alkalinity Ratio

## Solids Produced

- ◎ *Example:* A primary clarifier receives a flow of 1.82 MGD with SS conc. Of 345 mg/L. If the clarifier effluent has a SS concentration of 190 mg/L, how many pounds of solids are generated daily?
- ◎ First, subtract 345 mg/L – 190 mg/L to get SS removal.
- ◎ Then, plug that conc. Into the POUNDS FORMULA:
- ◎ (SS removed, mg/L)(Flow, MGD)(8.34 lbs/gal) = SS Removed, lbs/day
- ◎ (155 mg/L)(1.82MGD)(8.34 lbs/gal) = SS Removed, lbs/day
- ◎ 2353 lbs/day SS removed

## Solids Thickening

- ◎ Thickening the sludge reduces the load on subsequent processes
  - Gravity thickener
    - A gravity thickener will thicken or concentrate sludges before they are sent to a digester, conditioning, or dewatering facility.
    - Are typically circular in shape (look like a clarifier), therefore the sq ft area is the area of a circle:  $(0.785)(D^2)$
  - Gravity belt
  - Dissolved Air Flotation (DAF)



Typical DAF Flow Diagram

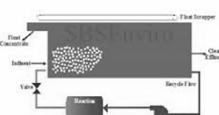

## Gravity Thickening

- Example: A primary sludge flow equivalent to 115,200 pgd is pumped to a 40 ft. diameter gravity thickener. If the solids conc. is 3.7%, what is the solids loading rate?

Simplified equation (ABC Formula Book):

- Solids loading rate, lbs/day/sq ft =  $\frac{\text{Solids Applied, lbs/day}}{\text{Area, sq ft}}$

Expanded formula:

- Solids loading rate, lbs/day/sq ft =  $\frac{(\text{Sludge, } \frac{\text{gal}}{\text{day}})(8.34 \frac{\text{lbs}}{\text{gal}})(\text{Solids Conc, \% as decimal})}{\text{Area, sq ft}}$

- Solids loading rate, lbs/day/sq ft =  $\frac{(115,200 \frac{\text{gal}}{\text{day}})(8.34 \frac{\text{lbs}}{\text{gal}})(0.037)}{(0.785)(40 \text{ ft})(40 \text{ ft})}$

- Solids loading rate =  $\frac{35548.416}{1256}$

- Solids loading rate = 28 lbs/day/sq ft.

## Gravity Thickening

- Efficiency is a measure of the effectiveness in removing suspended solids from the flow
  - Efficiency is determined by % removal
- Example: The sludge flow entering a gravity thickener contains 3.1% solids. The effluent from the thickener contains 0.18% solids. What is the efficiency of the gravity thickener in removing solids?

- Removal, % =  $\left(\frac{In - Out}{In}\right) \times 100\%$

- Removal, % =  $\frac{3.1 - 0.18}{3.1} \times 100$

- Removal, % =  $\frac{2.92}{3.1} \times 100$

- Removal = 94 %



## Volatile Solids to the Digester

- ⊙ When calculating % volatile solids, the “part” of interest is the weight of the volatile solids; the “whole” is the weight of total solids:
- ⊙  $\% \text{ Volatile Solids} = \frac{\text{Volatile Solids, lbs/day}}{\text{Total Solids, lbs/day}} \times 100$
- ⊙ To calculate lbs/day volatile solids to the digester, this equation can be rearranged as:
- ⊙  $(\text{Total Solids, lbs/day})\left(\frac{\% \text{ Volatile Solids}}{100}\right) = \text{Volatile Solids, lbs/day}$
- Or
- ⊙  $(\text{Total Solids, lbs/day})(\text{Volatile Solids Conc, \% , as a decimal}) = \text{Volatile Solids, lbs/day}$

## Volatile Solids to Digester

- ⊙ *Example:* If 1480 lbs/day solids are sent to the digester, with a volatile solids content of 70%, how many lbs/day volatile solids are sent to the digester?
- ⊙  $(\text{Total Solids, lbs/day})(\text{Volatile Solids Conc, \% , as a decimal}) = \text{Volatile Solids, lbs/day}$
- ⊙  $(1480 \text{ lbs/day})(0.70) = \text{Volatile Solids, lbs/day}$
- ⊙ 1036 lbs/day Volatile Solids

## Digester Loading Rate

- ⦿ A measure of the lbs volatile solids/day entering each cubic foot of digester volume.

Simplified Equation:

- ⦿ Digester Loading =  $\frac{\text{VS Added, lbs/day}}{\text{Volume, cu ft}}$

Expanded Equation:

- ⦿ Digester Loading, lbs/day/cu ft = 
$$\frac{(\text{Sludge, } \frac{\text{lbs}}{\text{day}})(\% \text{ Solids})(\% \text{ VS})}{(0.785)(D^2)(\text{Water Depth, ft})}$$

## Digester Loading Rate

- ⦿ *Example:* A digester 40 ft in diameter with a water depth of 20 ft receives 84,000 lbs/day raw sludge. If the sludge contains 6.5% solids with 70% volatile matter, what is the digester loading in lbs VS added/day/cu ft volume?

- ⦿ Digester Loading, lbs/day/cu ft = 
$$\frac{(\text{Sludge, } \frac{\text{lbs}}{\text{day}})(\% \text{ Solids})(\% \text{ VS})}{(0.785)(D^2)(\text{Water Depth, ft})}$$

- ⦿ Digester Loading = 
$$\frac{(84,000 \frac{\text{lbs}}{\text{day}})(0.065)(0.70)}{(0.785)(40 \text{ ft})(40 \text{ ft})(20 \text{ ft})}$$

- ⦿ Digester Loading = 0.15 lbs VS/day/cu ft.

## Volatile Acid/Alkalinity Ratio

- ◎ Anaerobic Digestion happens in 2 stages:
  1. Acid fermentation: Acid producing bacteria make volatile fatty acids
  2. Methane fermentation: Methanogens produce methane
    - Requires a more alkaline environment
- ◎ VA/Alk Ratio is an indicator of the balance between the 2 stages
  - Your first indicator that your digester is going sour
  - If digester goes sour, lime neutralization may be necessary
    - Generally each mg/L volatile acid requires 1 mg/L of lime

|   |              |                          |
|---|--------------|--------------------------|
| $\text{VA/Alk Ratio} = \frac{\text{Volatile Acids,mg/L}}{\text{Alkalinity,mg/L}}$ | Optimum      | V.A./ALK = .05 - 0.1     |
|   | Stress       | V.A./ALK = 0.3 - 0.4     |
|   | Deep Trouble | V.A./ALK = 0.5 - 0.7     |
|   | Failure      | V.A./ALK = 0.8 and above |

## Volatile Acid/Alkalinity Ratio

- ◎ *Example:* The volatile acid concentration of the sludge in the anaerobic digester is 160 mg/L. If the alkalinity is measured as 2280 mg/L, what is the VA/Alk ratio?
- ◎  $\text{VA/Alk Ratio} = \frac{\text{Volatile Acids,mg/L}}{\text{Alkalinity,mg/L}}$
- ◎  $\text{VA/Alk Ratio} = \frac{160 \text{ mg/L}}{2280 \text{ mg/L}}$
- ◎  $\text{VA/Alk Ratio} = 0.07$

## % Volatile Solids Reduction

- One of the best indicators of the effectiveness of the digestion process.
- When volatile solids are expressed as pounds, use the % Removal formula.
- But when volatile solids are expressed as %, use % Reduction of Volatile Solids formula:
- % Reduction of Volatile Solids =  $\left(\frac{VS_{in} - VS_{out}}{VS_{in} - (VS_{in} \times VS_{out})}\right) \times 100$

\*\*\*Everything must be in decimal form\*\*\*

## % Volatile Solids Reduction

- Example:* The sludge entering a digester has a volatile solids content of 70%. The sludge leaving the digester has a volatile solids content of 52%. What is the percent volatile solids reduction?
- % Reduction of Volatile Solids =  $\left(\frac{VS_{in} - VS_{out}}{VS_{in} - (VS_{in} \times VS_{out})}\right) \times 100$
- % Reduction of Volatile Solids =  $\left(\frac{0.70 - 0.52}{0.70 - (0.70 \times 0.52)}\right) \times 100$
- % Reduction of Volatile Solids = 54%

## Volatile Solids Destroyed

- One measure of digester effectiveness is pounds of volatile solids reduced or destroyed per cubic feet of digester volume.

Simplified Equation:

- $$\text{Volatile Solids Destroyed, lbs/day/cu ft} = \frac{\text{VS Destroyed, lbs/day}}{\text{Digester Volume, cu ft}}$$

Expanded Equation:

Volatile Solids Destroyed, lbs/day/cu ft =

$$\frac{(\text{Sludge, gpd}) \left(8.34 \frac{\text{lbs}}{\text{gal}}\right) (\text{Solids Conc, \%}) (\text{VS Conc, \%}) (\text{VS Reduced, \%})}{(0.785) (\text{Diameter, ft})^2 (\text{Depth, ft})}$$

\*\*\*Everything must be in decimal form\*\*\*

## Volatile Solids Destroyed

- Example:* A flow of 3300 gpd sludge is pumped to a 32,000 cu ft digester. The solids concentration of sludge is 6.3%, with a volatile solids content of 72%. If the volatile solids reduction during digestion is 54%, how many lbs/day volatile solids are destroyed per cu ft of digester capacity?

- Volatile Solids Destroyed, lbs/day/cu ft =

$$\frac{(\text{Sludge, gpd}) \left(8.34 \frac{\text{lbs}}{\text{gal}}\right) (\text{Solids Conc, \%}) (\text{VS Conc, \%}) (\text{VS Reduced, \%})}{(0.785) (\text{Diameter, ft})^2 (\text{Depth, ft})}$$

- = 
$$\frac{(3300 \text{ gpd}) \left(8.34 \frac{\text{lbs}}{\text{gal}}\right) (0.063) (0.72) (0.54)}{32,000 \text{ cu ft}}$$

- = 0.021 lbs VS/day/cu ft Volatile Solids Destroyed

## Digester Gas Production

- ⊙ The volume and composition of gas produced is important for:
  1. An indicator of the progress of digestion
    - 2<sup>nd</sup> stage of anaerobic digestion: methane fermentation
  2. It's utilization as fuel for the plant
    - Must contain 62% methane to be used as fuel
- ⊙ Normally gas production is 12-18 ft<sup>3</sup> for every pound of volatile matter destroyed

Simplified Equation:

$$\odot \text{ Digester Gas production} = \frac{\text{Gas produced, cu ft/day}}{\text{VS Destroyed, lbs/day}}$$

Expanded Equation:

$$\odot \text{ Digester Gas production} = \frac{\text{Gas Produced, cu ft/day}}{\left(\text{VS to Digester, } \frac{\text{lbs}}{\text{day}}\right) (\% \text{ VS Reduction, } \%)}$$

## Digester Gas Production

- ⊙ *Example:* A total of 1900 lbs of volatile solids are pumped to the digester daily. If the % reduction of volatile solids due to digestion is 60% and the average gas production for the day is 18,240 cu ft, what is the daily gas production in cu ft/lb destroyed daily?

$$\odot \text{ Digester Gas production} = \frac{\text{Gas Produced, cu ft/day}}{\left(\text{VS to Digester, } \frac{\text{lbs}}{\text{day}}\right) (\% \text{ VS Reduction, } \%)}$$

$$\odot \text{ Digester Gas production} = \frac{18,240 \text{ cu ft/day}}{\left(1900 \frac{\text{lbs}}{\text{day}}\right) (0.60)}$$

$$\odot \text{ Digester Gas production} = 16 \text{ cu ft gas produced per lb VS destroyed}$$

## Digestion Time

- Flow-through time in the digester
  - Simply a Detention Time calculation

Simplified Equation:

- Digestion Time, days =  $\frac{\text{Digester Volume, gal}}{\text{Sludge Flow Rate, gpd}}$

Expanded Equation:

- Digestion Time, days =  $\frac{(0.785)(D^2)(\text{Depth,ft})(7.48\frac{\text{gal}}{\text{cu}}\text{ft})}{\text{Sludge Flow Rate, gpd}}$

## Digestion Time

- *Example:* A 50 ft. diameter aerobic digester has a side water depth of 12 ft. The sludge flow to the digester is 9000 gpd. Calculate the digestion time.

- Digestion Time, days =  $\frac{(0.785)(D^2)(\text{Depth,ft})(7.48\frac{\text{gal}}{\text{cu}}\text{ft})}{\text{Sludge Flow Rate, gpd}}$

- Digestion Time, days =  $\frac{(0.785)(50\text{ft})(50\text{ft})(12\text{ft})(7.48\frac{\text{gal}}{\text{cu}}\text{ft})}{9000\text{ gpd}}$

- Digestion Time = 19.6 days

## pH Adjustment with Jar Tests

- ⦿ The pH of aerobic digesters should not drop below 6.0, neutralization may be necessary sometimes.
  - ⦿ To determine pounds of lime/caustic needed, use the POUNDS formula.
- To determine lime/caustic dosage:
- ⦿ Solids concentration, mg/L =  $\frac{\text{Weight,mg}}{\text{Volume,L}}$

## pH Adjustment with Jar Tests

- ⦿ *Example:* A 2 liter sample of digested sludge is used to determine the required caustic dosage for pH adjustment. If 56 mg of caustic are required for pH adjustment in the jar test, and the digester volume is 94,000 gallons, how many pounds of caustic will be required for pH adjustment?
- ⦿ First, determine mg/L caustic dosage:
- ⦿ Solids concentration, mg/L =  $\frac{\text{Weight,mg}}{\text{Volume,L}}$
- ⦿ Solids concentration, mg/L =  $\frac{56 \text{ mg}}{2 \text{ L}}$
- ⦿ = 28 mg/L caustic
- ⦿ Then, the pounds caustic required can be calculated:
- ⦿ (28 mg/L)(0.094 MG)(8.34 lbs/gal) = 22.0 lbs caustic



Any Questions?

## Applied Math for Wastewater Treatment Sludge Digestion

### **Solids Produced, lbs/day**

1. The suspended solids content of the primary influent is 360 mg/L and the primary effluent is 208 mg/L. How many pounds of solids are produced during a day that that flow is 4,220,000 gpd?

### **Solids Loading Rate, lbs/day/sq ft (Gravity Thickening)**

2. A primary sludge flow equivalent to 243,000 gpd is pumped to a 50 foot diameter gravity thickener. If the solids concentration of the sludge is 4.4%, what is the solids loading in lbs/day/sq ft?

### **Efficiency or Removal, % (Gravity Thickening)**

3. The sludge flow entering a gravity thickener contains 2.9% solids. The effluent from a thickener contains 0.14% solids. What is the efficiency of the gravity thickener in removing solids?

### **Volatile Solids to Digester, lbs/day**

4. If 1620 lbs/day solids are sent to the digester, with a volatile solids content of 65%, how many lbs/day volatile solids are sent to the digester?

**Digester Loading Rate, lbs VS added/day/ft<sup>3</sup>**

5. What is the digester loading if a digester, 45 feet in diameter with a liquid level of 20 feet, receives 82,500 lbs/day of sludge with 5.8% solids and 69% volatile solids?

**Volatile Acids/Alkalinity Ratio**

6. The volatile acids concentration of the sludge in an anaerobic digester is 170 mg/L. If the measured alkalinity is 2150 mg/L, what is the VA/Alkalinity ratio?

**Lime Neutralization**

7. The digester sludge is found to have a volatile acids content of 3055 mg/L. If the digester volume is 200,000 gallons, how many pounds of lime will be required for neutralization?

**Percent Volatile Solids Reduction**

8. The raw sludge to a digester has a volatile solids content of 69%. The digested sludge volatile solids content is 53%. What is the percent volatile solids reduction?

**Volatiles Solids Destroyed, lbs VS/day/ft<sup>3</sup>**

9. A flow of 3750 gpd sludge is pumped to a 35,000-ft<sup>3</sup> digester. The solids concentration of the sludge is 6.3% with a volatile solids content of 68%. If the volatile solids reduction during digestion is 54%, how many lbs/day volatile solids are destroyed per ft<sup>3</sup> of digester capacity?

**Digester Gas Production, ft<sup>3</sup> Gas Produced/lb VS destroyed**

10. The anaerobic digester at a treatment plant receives a total of 10,500 gpd of raw sludge. This sludge has a solids content of 5.3% of which 64% is volatile. If the digester yields a volatile solids reduction of 61% and the average digester gas production is 22,300 ft<sup>3</sup>, what is the daily gas production in ft<sup>3</sup>/lb VS destroyed daily?

**Digestion Time, days**

11. An aerobic digester 40-ft in diameter has a side water depth of 12 ft. The sludge flow to the digester is 8200 gpd. Calculate the hydraulic detention time in days.

**pH Adjustments Using Jar Tests**

12. A 2 liter sample of digested sludge is used to determine the required caustic dosage for pH adjustment. If 47 mg of caustic are required for pH adjustment in the jar test, and the digester volume is 86,000 gallons, how many pounds of caustic will be required for pH adjustment?

**Answers:**

1. 5350 lbs/day
2. 45.44 lb/day/ft<sup>2</sup>
3. 95.17%
4. 1053 lb/day
5. 0.10 lb/day/ft<sup>3</sup>
6. 0.0791
7. 5095.74 lbs
8. 49.3%
9. 0.021 lb/day/ft<sup>3</sup>
10. 12.31 ft<sup>3</sup>/lbs VS destroyed
11. 13.75 days
12. 16.86 lbs

## Applied Math for Wastewater Treatment Sludge Digestion – Additional Problems

### Solids Produced, lbs/day

1. The suspended solids content of the primary influent is 215 mg/L and the primary effluent is 98 mg/L. How many pounds of solids are produced during a day that the flow is 3,393,000 gpd?
2. A primary clarifier receives a flow of 4.82 MGD with a suspended solids concentration of 291 mg/L. If the clarifier effluent has a suspended solids concentration of 131 mg/L, how many lb of dry solids are generated daily?
3. The suspended solids concentration of a primary influent is 315 mg/L and that of the primary effluent is 131 mg/L. How many pounds of dry solids are produced if the flow is 3.9 MGD?

### Solids Loading Rate, lbs/day/sq ft (Gravity Thickening)

4. A primary sludge flow equivalent to 987,000 gpd is pumped to a 95 foot gravity thickener. If the solids concentration of the sludge is 3.9%. what is the solids loading in lbs/day/sq ft?

5. A primary sludge flow equivalent to 122,000 gpd is pumped to a 44 foot diameter gravity thickener. If the solids concentration of the sludge is 4.1%, what is the solids loading in lbs/day/sq ft?
  
  
  
  
  
  
  
  
  
  
6. What is the solids loading (in lbs/day/sq ft) on a gravity thickener if the primary sludge flow to the 32 foot diameter gravity thickener is 60 gpm, with a solids concentration of 3.8%?
  
  
  
  
  
  
  
  
  
  
7. What is the solids loading on a gravity thickener if the primary sludge flow to the 35 foot diameter gravity thickener is 55 gpm, with a solids concentration of 3.5%?

**Efficiency or Removal, % (Gravity Thickening)**

8. The sludge flow entering a gravity thickener contains 4.5% solids. The effluent from the thickener contains 0.19% solids. What is the efficiency of the gravity thickener in removing solids?
  
  
  
  
  
  
  
  
  
  
9. What is the efficiency of the gravity thickener if the influent flow to the thickener has a sludge solids concentration of 4% and the effluent flow has a sludge solids concentration of 0.9%?

10. The sludge flow entering a gravity thickener contains 3.5% sludge solids. The effluent from the thickener contains 0.8% sludge solids. What is the efficiency of the gravity thickener in removing sludge solids?

**Volatile Solids to Digester, lbs/day**

11. If a 8,250 lbs/day of solids with a volatile solids content of 68% are sent to the digester, how many lbs/day volatile solids are sent to the digester?
12. A total of 3600 gpd of sludge is pumped to the digester. If the sludge has a 5.7% solids content with 71% volatile solids, how many lbs/day volatile solids are pumped to the digester?
13. If 2810 lbs/day of solids with a volatile solids content of 67% are sent to the digester, how many lbs/day volatile solids are sent to the digester?
14. If 8620 lbs/day of solids with a volatile solids content of 66% are sent to the digester, how many lbs/day volatile solids are sent to the digester?



15. A sludge has a 7% solids content with 67% volatile solids. If 5115 gpd of sludge are to be pumped to the digester, how many lb/day of volatile solids are pumped in the digester?

**Digester Loading Rate, lbs VS added/day/ft<sup>3</sup>**

16. A digester 50 ft in diameter with a water depth of 22 ft receives 86,100 lbs of raw sludge per day. If the sludge contains 5% solids and 70% is volatile solids, what is the digester loading in lbs VS added/day/ft<sup>3</sup>?
17. What is the digester loading in lbs VS added/day/ft<sup>3</sup> if a digester that is 40 ft in diameter with a liquid level of 22 ft receives 28,500 gpd of sludge with 5.6% solids and 72% volatile solids? Assume the sludge weighs 8.34 lbs/gal.
18. A digester that is 50 ft in diameter with a liquid level of 20 ft receives 36,220 gpd of sludge with 5.6% solids and 68% volatile solids. What is the digester loading in lbs VS added/day/ft<sup>3</sup>? Assume the sludge weighs 8.34 lbs/gal.

19. A digester that is 50 ft in diameter with a liquid level of 18 ft receives 16,200 gpd of sludge with 5.1% solids and 72% volatile solids. What is the digester loading in lbs VS added/day/ft<sup>3</sup>?
20. A digester, 40-ft in diameter with a liquid level of 18 ft receives 26,400 gpd of sludge with 5.7% solids and 71% volatile solids. What is the digester loading in lbs VS added/day/ft<sup>3</sup>?

### **Volatile Acids/Alkalinity Ratio**

21. The volatile acids concentration of the sludge in an anaerobic digester is 174 mg/L. If the measured alkalinity is 2220 mg/L, what is the VA/Alkalinity ratio?
22. The volatile acids concentration of the sludge in an anaerobic digester is 160 mg/L. If the measured alkalinity is 2510 mg/L, what is the VA/Alkalinity ratio?
23. The measured alkalinity is 2410 mg/L. If the volatile acids concentration of the sludge in an anaerobic digester is 144 mg/L, what is the VA/Alkalinity ratio?

24. The measured alkalinity is 2620 mg/L. If the volatile acids concentration of the sludge in an anaerobic digester is 178 mg/L, what is the VA/Alkalinity ratio?
25. The desired VA/Alkalinity ratio for the anaerobic digester at a particular plant is 0.05. If the alkalinity is found to be 2800 mg/L, what is the desired volatile acids concentration of the digester sludge?

### **Lime Neutralization**

26. To neutralize a sour digester, 1 mg/L of lime is added for every mg/L of volatile acids in the digester sludge. If the digester contains 250,000 gallons of sludge with a volatile acid level of 2300 mg/L, how many pounds of lime should be added?
27. If the digester sludge contains 244,000 gallons of sludge with a volatile acid level of 2280 mg/L, how many lbs of lime should be added?

28. To neutralize a sour digester, 1 mg/L of lime is added for every mg/L of volatile acids in the digester sludge. If the digester sludge contains 200,000 gallons of sludge with a volatile acid level of 2010 mg/L, how many lbs of lime should be added?
29. A digester contains 234,000 gallons of sludge with a volatile acid level of 2540 mg/L. To neutralize a sour digester, 1 mg/L of lime is added for every mg/L of volatile acids in the digester sludge. How many lbs of lime should be added?
30. A digester sludge is found to have a volatile acids content of 2410 mg/L. If the digester volume is 182,000 gallons, how many lbs of lime will be required for neutralization?

### **Percent Volatile Solids Reduction**

31. The raw sludge to a digester has a volatile solids content of 72%. The digested sludge volatile solids content is 46%. What is the percent volatile solids reduction?
32. Sludge entering a digester has a volatile solids content of 68%. Sludge leaving the digester has a volatile solids content of 52%. What is the percent volatile solids reduction?

33. Sludge leaving a digester has a volatile solids content of 54%. Sludge entering the digester has a volatile solids content of 70%. What is the percent volatile solids reduction?
34. The raw sludge to a digester has a volatile solids content of 70%. The digested sludge volatile solids content is 55%. What is the percent volatile solids reduction?
35. The volatile solids content of a digested sludge is 54%. The raw sludge to a digester has a volatile solids content of 69%. What is the percent volatile solids reduction?
36. If the sludge entering a digester has a VS content of 53.8% and the digester effluent sludge has a VS content of 40.1%, calculate the percent VS reduction.

**Volatiles Solids Destroyed, lbs VS/day/ft<sup>3</sup>**

37. A 50 foot diameter digester receives a sludge flow of 3300 gpd, with a solids content of 7% and a volatile solids concentration of 59%. The volatile solids reduction during digestion is 53%. The digester operates at a level of 20 feet. What is the lbs/day volatile solids reduction per cu ft of digester capacity?
38. A flow of 3800 gpd sludge is pumped to a 36,500 ft<sup>3</sup> digester. The solids concentration of the sludge is 6.3% with a volatile solids content of 73%. If the volatile solids reduction during digestion is 57%, how many lbs/day volatile solids are destroyed/ft<sup>3</sup> of digester capacity? Assume the sludge weighs 8.34 lbs/gal.
39. A flow of 4520 gpd sludge is pumped to a 34,000 ft<sup>3</sup> digester. The solids concentration of the sludge is 7% with a volatile solids content of 69%. If the volatile solids reduction during digestion is 54%, how many lbs/day volatile solids are destroyed/ft<sup>3</sup> of digester capacity? Assume the sludge weighs 8.34 lbs/gal.
40. A 50-ft diameter digester receives a sludge flow of 2600 gpd with a solids content of 5.6% and a volatile solids concentration of 72%. The volatile solids reduction during digestion is 52%. The digester operates at a level of 18 ft. What is the lbs/day volatile solids reduction/ft<sup>3</sup> of digester capacity? Assume the sludge weighs 8.34 lbs/gal.

41. The sludge flow to a 40-ft diameter digester is 2800 gpd with a solids concentration of 6.1% and a volatile solids concentration of 65%. The digester is operated at a depth of 17 ft. If the volatile solids reduction during digestion is 56%, what is the lbs/day volatile solids reduction per 1000 ft<sup>3</sup> of digester capacity? Assume the sludge weighs 8.34 lbs/gal.
42. A 50-ft diameter digester receives a sludge flow of 2800 gpd with a solids content of 5.8% and a volatile solids concentration of 70%. The volatile solids reduction during digestion is 54%. The digester operates at a level of 20 ft. What is the lbs/day volatile solids reduction per cu ft of digester capacity? Assume the sludge weighs 8.34 lbs/day.

**Digester Gas Production, ft<sup>3</sup> Gas Produced/lb VS destroyed**

43. A digester gas meter reading indicates an average of 6340 cu ft of gas is produced every day. If a total of 590 lbs/day volatile solids are destroyed, what is the digester gas production in cu ft gas/lb VS destroyed?
44. A total of 2060 lbs of volatile solids are pumped to the digester daily. If the percent reduction of volatile solids due to digestion is 57% and the average gas production for the day is 19,150 ft<sup>3</sup>, what is the daily gas production in ft<sup>3</sup>/lb VS destroyed daily?

45. A digester gas meter reading indicates that, on average, 6600 ft<sup>3</sup> of gas are produced per day. If 500 lbs/day volatile solids are destroyed, what is the digester gas production in ft<sup>3</sup>/lb VS destroyed?
46. A total of 2110 lbs of volatile solids are pumped to the digester daily. If the percent reduction of volatile solids due to digestion is 59% and the average gas production for the day is 19,330 ft<sup>3</sup>, what is the daily gas production in ft<sup>3</sup>/lb VS destroyed daily?
47. A total of 582 lbs/day of volatiles solids are destroyed. If a digester gas meter reading indicates that 8710 ft<sup>3</sup> of gas are produced per day, on average, what is the digester gas production in ft<sup>3</sup>/lb VS destroyed daily?
48. The percent reduction of volatile solids due to digestion is 54% and the average gas production for the day is 26,100 ft<sup>3</sup>. If 3320 lbs of volatile solids are pumped to the digester daily, what is the gas production in ft<sup>3</sup>/lb VS destroyed daily?



49. What must have been the gas production by a digester in  $\text{ft}^3/\text{day}$ , given the following data?

Volatile Solids destroyed = 428 lbs/day

Gas produced in  $\text{ft}^3/\text{lb}$  VS destroyed =  $11.8 \text{ ft}^3/\text{lb}$

**Digestion Time, days**

50. An aerobic digester 40-ft in diameter has a side water depth of 10 ft. The sludge flow to the digester is 8250 gpd. Calculate the hydraulic detention time in days.

51. A 40-ft aerobic digester has a side water depth of 12 feet. The sludge flow to the digester is 9100 gpd. Calculate the digestion time in days.

52. An aerobic digester is 80 ft long by 25 ft wide and has a side water depth of 12 ft. The sludge flow to the digester is 7800 gpd, what is the hydraulic digestion time, in days?

53. An aerobic digester is 90 ft long by 20 ft wide and has a side water depth of 10 ft. The sludge flow to the digester is 7600 gpd, what is the hydraulic digestion time, in days?
54. A 50-ft aerobic digester has a side water depth of 10 feet. The sludge flow to the digester is 9500 gpd. Calculate the digestion time in days.
55. What is the hydraulic digestion time for a digester that is 25.0 feet in radius, has a level of 13.7 feet, and has a sludge flow of 10,840 gallons per day?

### **pH Adjustments Using Jar Tests**

56. A 2 liter sample of digested sludge is used to determine the required caustic dosage for pH adjustment. A total of 62 mg caustic were used in the jar test. The aerobic digester is 45 feet in diameter with a side water depth of 10 feet. How many pounds of caustic are required for pH adjustment of the digester?

57. Jar tests indicate that 22 milligrams of caustic are required to raise the pH of a 1 liter sludge sample to 6.8. If the digester volume is 106,000 gallons, how many lbs of caustic are required for pH adjustment?
58. A 2 liter sample of digester sludge is used to determine the required dosage for pH adjustment. A total of 90 milligrams caustic was used in the jar test. The aerobic digester is 60 feet in diameter with a side water depth of 14 feet. How many lbs of caustic are required for pH adjustment of the digester?

**Answers:**

1. 3310.8215 lbs/day
2. 6431.81 lbs/day
3. 5984.78 lbs/day
4. 45.31 lbs/day
5. 27.45 lbs/day/sq ft
6. 34.06 lbs/day/sq ft
7. 24.04 lbs/day/sq ft
8. 95.78%
9. 77.5%
10. 77.14%
11. 5610 lbs VS/day
12. 1215.07 lbs VS/day
13. 1882.7 lbs VS/day
14. 5689.2 lbs VS/day
15. 2000.71 lbs VS/day
16. 0.07 lbs VS/day/cu ft
17. 0.35 lbs VS/day/cu ft
18. 0.29 lbs VS/day/cu ft
19. 0.14 lbs VS/day/cu ft
20. 0.39 lbs VS/day/cu ft
21. 0.078
22. 0.064
23. 0.060
24. 0.068
25. 140 mg/L
26. 4795.5 lbs
27. 4639.71 lbs
28. 3352.68 lbs
29. 4956.96 lbs
30. 3658.09 lbs
31. 66.87%
32. 49%
33. 49.69%
34. 47.62%
35. 47.26%
36. 42.51%
37. 0.0153 lbs VS/day/cu ft
38. 0.0228 lbs VS/day/cu ft
39. 0.0289 lbs VS/day/cu ft
40. 0.0129 lbs VS/day/cu ft
41. 24.3 lbs VS/day/1000 cu ft
42. 0.013 lbs VS/day/cu ft
43. 10.75 cu ft/lb VS destroyed
44. 16.31 cu ft/lb VS destroyed
45. 13.2 cu ft/lb VS destroyed
46. 15.5274 cu ft/lb VS destroyed
47. 14.9656 cu ft/lb VS destroyed
48. 14.5582 cu ft/lb VS destroyed
49. 5050.4 cu ft/day
50. 11.39 days
51. 12.39 days
52. 23.02 days
53. 17.7 days
54. 15.45 days
55. 18.55 days
56. 30.74 lbs
57. 19.45 lbs
58. 111.07 lbs